

Commercial and Industrial Aluminumcase Diaphragm Meters

Capacity Ratings from 800 scfh to 5000 scfh



AMC Quality System

QMI is Accredited by:



ISO 9002 Certified



Dutch Council
for Accreditation



AMERICAN METER COMPANY

Measurement Engineers Since 1836

Commercial and Industrial Aluminumcase Diaphragm Meters

American Meter has a strong commitment to supplying high-quality diaphragm meters that meet and exceed the requirements of the industry. Our pledge to continuously improve long-term performance and acceptability of our diaphragm meters has made us the leading supplier to the industry.

American Meter's compact, lightweight, aluminumcase meters are designed to provide positive displacement accuracy for industrial or commercial loads. The one-piece aluminum alloy body, top and covers provide durability and high resistance to impact damage.

Each model incorporates refinements in design and materials pioneered by American Meter to give the best in-service performance at lowest maintenance costs.

To eliminate lost revenue from inaccurate measurement of gas volumes due to temperature changes, every American meter is available with temperature compensation.

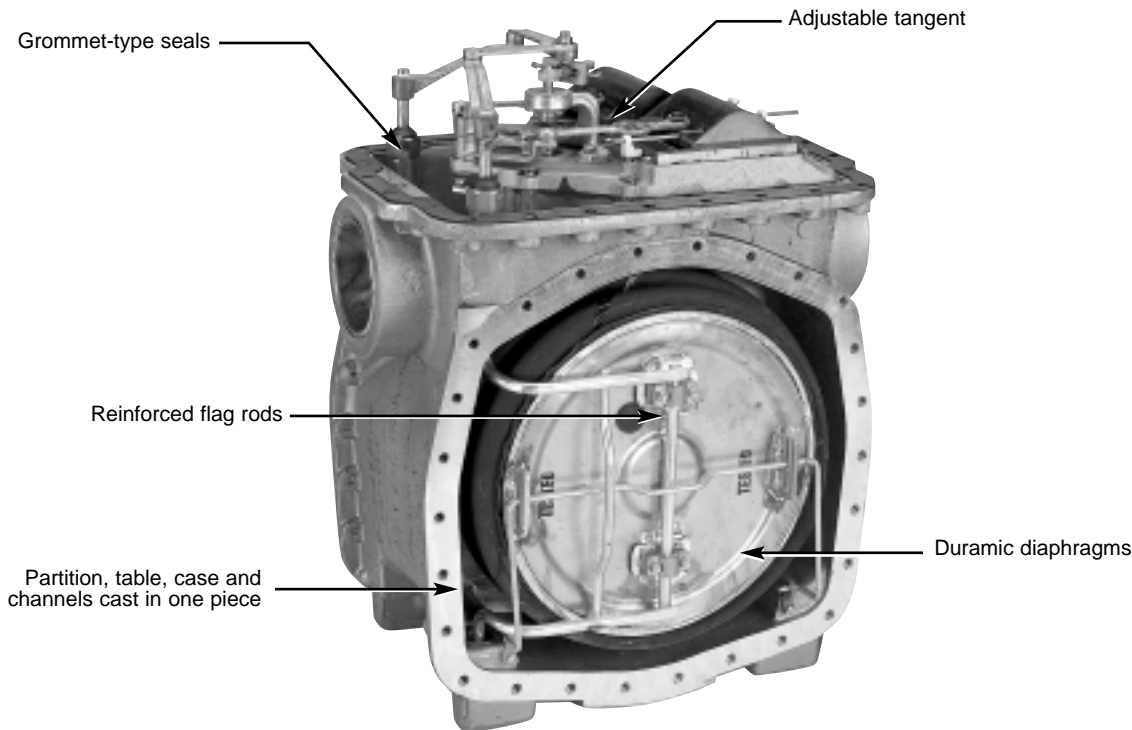

Features and Benefits

Lightweight and attractive meter

American Meter's light and compact aluminumcase diaphragm meter reduces handling, shipping, storing and setting costs. Modern styling and attractive appearance assure ready customer acceptance.

Valve material and design

The use of Durafil valves and the established American design of valve motion and related parts insures long-term proof stability and minimum wear.

Molded Duramic diaphragms

Molded, three-convolution Duramic diaphragms have uniform thickness and flexibility insuring smooth operation and long life with sustained accuracy for all fuel-gas services.

Low-friction seals

Synthetic grommet-type flag-rod seals provide minimum friction and show no leakage after millions of cycles.

Adjustable tangent

Completely adjustable tangent can be easily adjusted for proof (without the use of a soldering iron) through the meter-handhole opening. Temperature compensating tangents are also available for each meter size.

Rugged, flag rods

Heavy, rugged, reinforced flag rods insure positive alignment and sustained accuracy.

Large, self-lubricating bearings

Critical bearing points contain extra-large, oil-impregnated bushings that are self lubricating for the life of the meter.

Exterior-body treatment

A single-coat, polyester-powder finish exhibits extreme weather and chemical-penetration resistance.

Steel connection threads

Permanent-steel inserts eliminate thread galling.

Accessories

Every aluminumcase diaphragm meter may be equipped with a temperature-compensating tangent, pressure-compensating index or with a mechanical or electronic-volume corrector.

Choice of indexes

All American Meter aluminumcase diaphragm meters are available with English or metric-reading indexes. Either a pointer-type or digital (odometer-type) index makes for effortless reading.

Recommended Basic Metering Equipment

Shown below are the elements of a basic meter installation with associated equipment, including:

1. A filter to remove particles that might impair accuracy or cause undue maintenance of the downstream regulators or meter.
2. An upstream pressure regulator to bring the meter inlet pressure down to a lower, steady level.
3. A meter to totalize consumed volume.
4. An output-pressure regulator as required for the gas use.

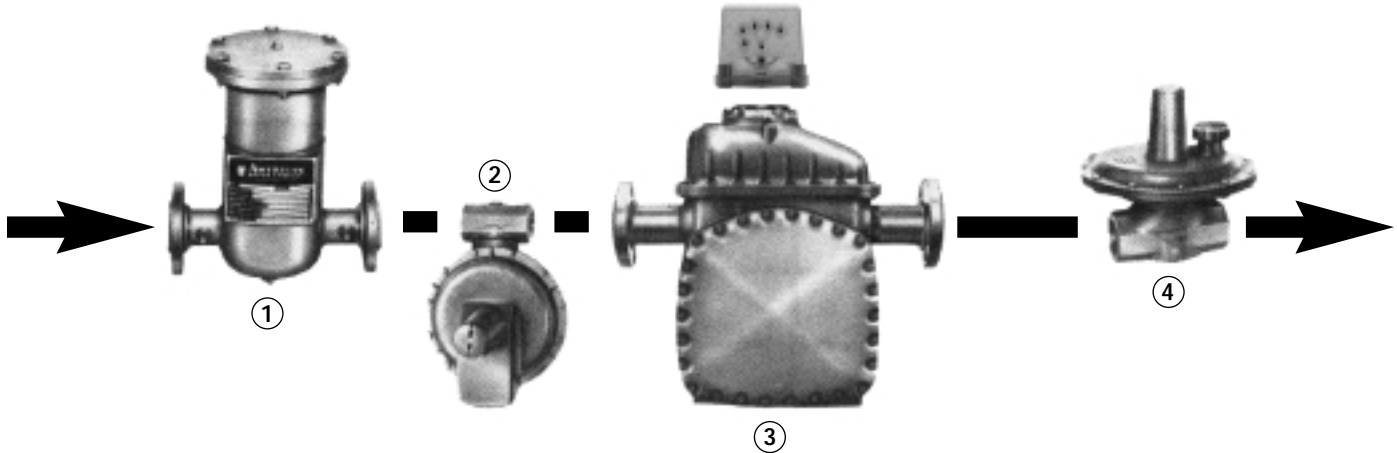

Systems for Gas Measurement

Remote Volume Pulsar (RVP) The American RVP Pulsar Transmitter uses a form 'A' type reed-switch mechanism to provide accurate pulse outputs for the complete range of American diaphragm meters. This range of pulsers is the basis of the American Meter AMR system and has been subjected to extensive life and environmental testing. See bulletin IMP 6771 for complete information on the RVP.

Local Indication Only American Meter offers various index types for local totalization of gas flow. Shown below are a standard circle-type index, a metric-odometer index, and a pressure-compensating index. See bulletin PL 3800 for a complete listing of indexes available.



Standard, circle-type index



Metric-odometer index



Pressure-compensating index

Facts on Temperature Compensation

The ability to accurately measure a gas at base temperature volume with a temperature compensated meter is determined by percent registration and not proof. Percent registration is the meter reading for 100 standard cubic feet of gas passed. In order for a meter to fulfill this function of compensating, its proof has to be automatically and continuously adjusted to equal:

$$\frac{100 \times \text{Meter Temperature (absolute)}}{\text{Base Temperature (absolute)}}$$

This is shown in the graph below where a standard meter without temperature compensation measures the amount of gas passing through it at temperatures other than base temperature, as a volume at meter temperature. A temperature-compensating meter measures gas passing through it, at any temperature, as the volume of gas at base temperature.

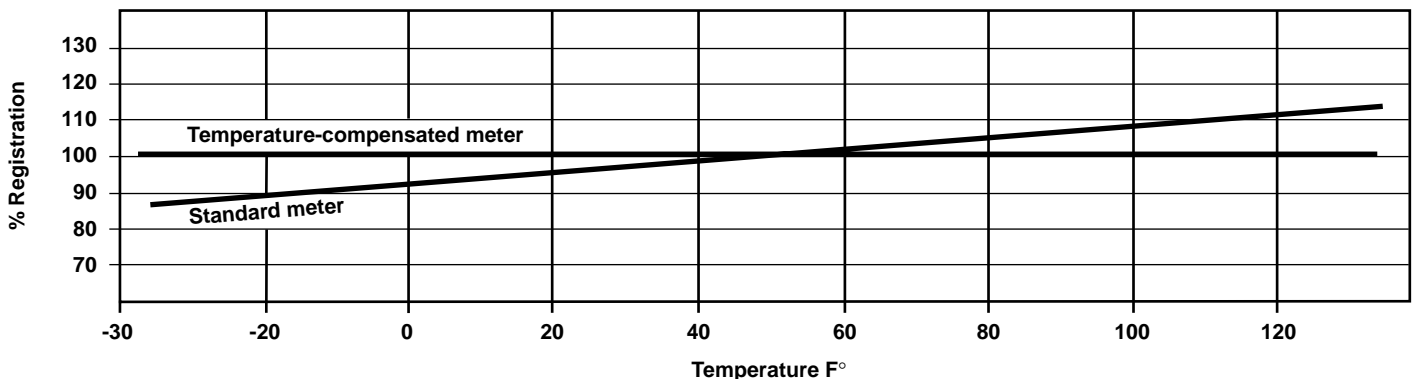

AL-800 and AL-1000 Aluminumcase Diaphragm Meters

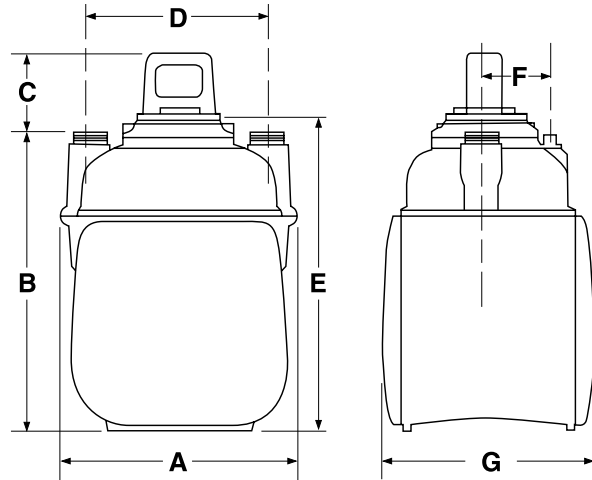
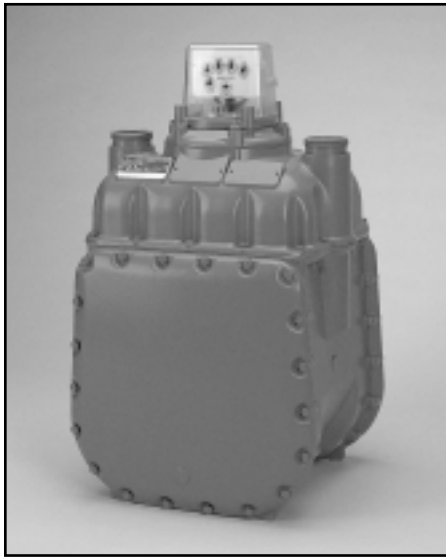

Meter Model MAOP		AL-800		AL-1000	
Inlet Pressure (psig)	Differential Pressure (in. w.c.)	20 psig	100 psig	25 psig	100 psig
		Meter Capacity (scfh) For 0.60 S.G. Gas			
0.25	1/2	800	800	1,000	1,000
0.25	2	1,700	1,700	2,200	2,200
5	2	2,100	2,100	2,700	2,700
10	2	2,600	2,600	3,400	3,400
15	2	2,800	2,800	3,700	3,700
20	2	3,200	3,200	4,100	4,100
25	2	-	3,500	4,600	4,600
30	2	-	3,800	-	5,000
50	2	-	5,100	-	6,600
75	2	-	6,500	-	8,400
100	2	-	7,800	-	10,100
Cubic Feet Per Revolution		5/13			
Proving Circle Volume (English)		5 ft ³ or 10 ft ³			
Proving Circle Volume (Metric)		0.1 m ³			
Undergear Ratio (English)		13:1 (5 ft ³) or 26:1 (10 ft ³)			
Undergear Ratio (Metric)		9:1			
Installation Instructions Bulletin		IM 3701			
Parts List Bulletin		RPL 3807			

MAOP (psig)	Dimensions (inches)							Weight lbs.	Connections
	A	B	C	D	E	F	G		
AL-800									
20	14.12	18.50	4.81	11.00	19.12	4.38	13.25	50	1-1/4"-30 LT 1-1/2"-45 LT #3-4 Sprague
20	14.12	19.19	4.19	11.00	19.12	4.38	13.25	50	1-1/2" NPT (F)
100	14.62	18.75	5.19	11.00	19.75	4.38	16.62	70	1-1/2" NPT (F)
100	14.62	19.81	4.12	11.00	19.75	4.38	16.62	70	#3-4 Sprague
AL-1000									
25	14.12	18.50	4.81	11.00	19.12	4.38	13.25	54	1-1/2"-45 LT 1-1/2" NPT (F)
25	14.12	19.25	4.06	11.00	19.12	4.38	13.25	54	2"-100 LT
25	14.12	20.25	3.06	11.00	19.12	4.38	13.25	54	#5 Sprague
100	14.62	18.75	5.19	11.00	19.75	4.38	16.62	78	1-1/2" NPT (F)

AL-1400 Aluminumcase Diaphragm Meters

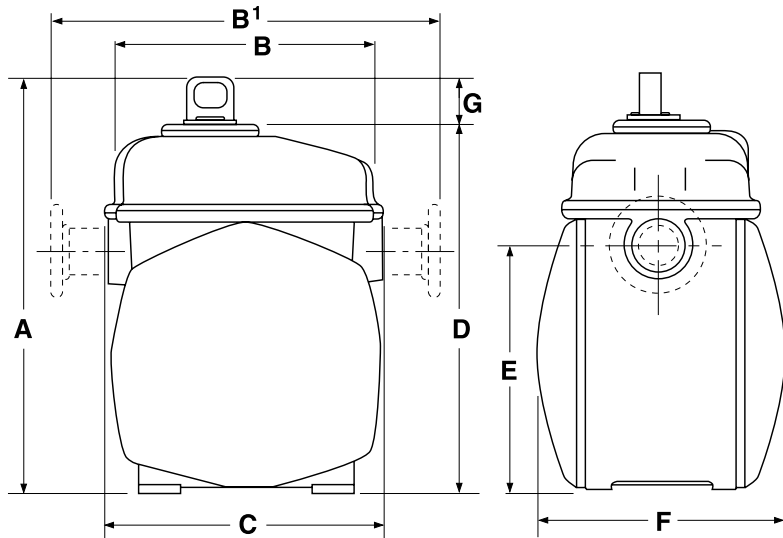

Meter Model MAOP		AL-1400
Inlet Pressure (psig)	Differential Pressure (in. w.c.)	100 psig
		Meter Capacity (scfh) For 0.60 S.G. Gas
0.25	1/2	1,400
0.25	2	3,000
5	2	3,700
10	2	4,600
15	2	5,000
20	2	5,600
25	2	6,200
30	2	6,800
50	2	9,000
75	2	11,500
100	2	13,800
Cubic Feet Per Revolution		5/7
Proving Circle Volume (English)		5 ft ³ or 10 ft ³
Proving Circle Volume (Metric)		0.1 m ³
Undergear Ratio (English)		7:1 (5 ft ³) or 14:1 (10 ft ³)
Undergear Ratio (Metric)		5:1
Installation Instructions Bulletin		IM 3701
Parts List Bulletin		RPL 3808

MAOP (psig)	Dimensions (inches)								Weight lbs.	Connections
	A	B	B ¹	C	D	E	F	G		
AL-1400										
100	28.88	17.25	-	17.38	24.62	15.00	15.88	4.25	120	2" NPT(F)
100	28.88	17.25	-	15.75	24.62	15.00	15.88	4.25	120	3" NPT (F)
100	28.88	-	28.00	-	24.62	15.00	15.88	4.25	132	3" Flanged

AL-2300 Aluminumcase Diaphragm Meters

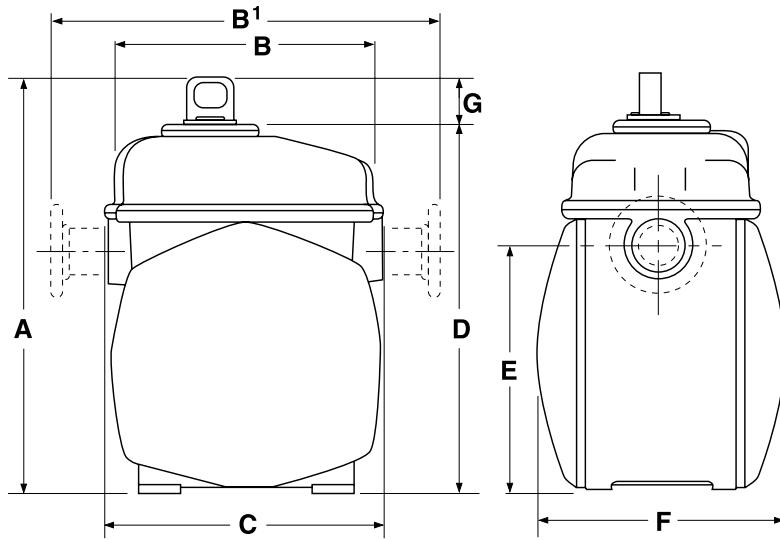

Meter Model MAOP		AL-2300
Inlet Pressure (psig)	Differential Pressure (in. w.c.)	100 psig
		Meter Capacity (scfh) For 0.60 S.G. Gas
0.25	1/2	2,300
0.25	2	5,000
5	2	6,200
10	2	7,700
15	2	8,400
20	2	9,400
25	2	10,400
30	2	11,400
50	2	15,000
75	2	19,100
100	2	23,000
Cubic Feet Per Revolution		1-1/4
Proving Circle Volume (English)		10 ft ³ or 100 ft ³
Proving Circle Volume (Metric)		0.1 m ³ or 1.0 m ³
Undergear Ratio (English)		8:1 (100 ft ³) or 80:1 (100 ft ³)
Undergear Ratio (Metric)		2.8:1 (0.1 m ³) or 28:1 (1.0 m ³)
Installation Instructions Bulletin		IM 3701
Parts List Bulletin		RPL 3809

MAOP (psig)	Dimensions (inches)								Weight lbs.	Connections
	A	B	B ¹	C	D	E	F	G		
AL-2300										
100	33.31	21.00	-	21.62	29.06	17.88	18.25	4.25	175	4" NPT(F)
100	-	-	32.00	-	-	-	-	-	192	4" Flanged

AL-5000 Aluminumcase Diaphragm Meters

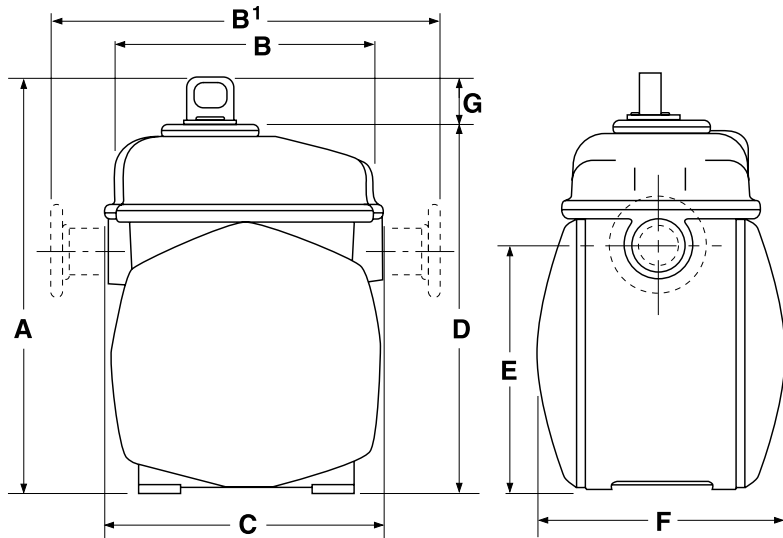

Meter Model MAOP		AL-5000
Inlet Pressure (psig)	Differential Pressure (in. w.c.)	100 psig
		Meter Capacity (scfh) For 0.60 S.G. Gas
0.25	1/2	5,000
0.25	2	11,000
5	2	13,500
10	2	17,000
15	2	18,500
20	2	20,600
25	2	23,000
30	2	25,000
50	2	33,000
75	2	42,000
100	2	50,500
Cubic Feet Per Revolution		2-6/7
Proving Circle Volume (English)		10 ft ³ or 100 ft ³
Proving Circle Volume (Metric)		1.0 m ³
Undergear Ratio (English)		3.5:1 (100 ft ³) or 35:1 (100 ft ³)
Undergear Ratio (Metric)		12.3:1
Installation Instructions Bulletin		IM 3701
Parts List Bulletin		RPL 3810

MAOP (psig)	Dimensions (inches)								Weight lbs.	Connections
	A	B	B¹	C	D	E	F	G		
AL-5000										
100	40.00	26.25	-	26.00	35.75	23.38	23.62	4.25	310	4" NPT(F)
100	-	-	32.00	-	-	-	-	-	327	4" Flanged

Commercial and Industrial Aluminumcase Diaphragm Meters

Ordering Information

1. Model
2. Working pressure
3. Temperature compensation (if required)
4. Connections
5. Type of index
6. Type of index box
7. Required proof
8. Meter finish – type and finish

A Complete Family of Gas Measurement, Pressure Regulation, and Testing Systems



Turbine Gas Meters

High-performance meters provide accurate measurement of high-volume gas flow. Turbines are available from 3" to 12" line sizes and line pressures up to 1440 psig.



Electronic Instruments

Electronic correction of temperature or pressure or both at the meter. Data can be accessed via the unit's display, downloaded to a personal computer or transmitted via modem.



Pressure Regulators

Inlet- and outlet-pressure regulators with a wide range of capacities. These regulators have optional overpressure and underpressure shutoff and full-capacity internal relief.



Test Apparatus

SNAP – The Sonic Nozzle Auto Prover provides unparalleled speed and accuracy in gas-meter proving.

American Meter Company is committed to a program of continuous quality enhancement. All equipment designed and manufactured by American Meter Company benefits from the company's quality assurance standards, which are approved to ISO 9001 or ISO 9002.

American Meter Company has a program of continuous product development and improvement; and, therefore, the information in this bulletin is subject to change or modification without notice.



AMERICAN METER

300 Welsh Road
Building One
Horsham, PA 19044-2234 U.S.A.
Phone: 215/830-1800
Fax: 215/830-1890



CANADIAN METER

3037 Derry Road, West
Milton, Ontario L9T 2X6 Canada
Phone: 905/878-2361
Fax: 905/878-5758

Website: americanmeter.com