

SB-8520.2

1800CPB2 Service Regulators

Maximum Inlet Pressure 125 PSIG

AMERICAN METER COMPANY

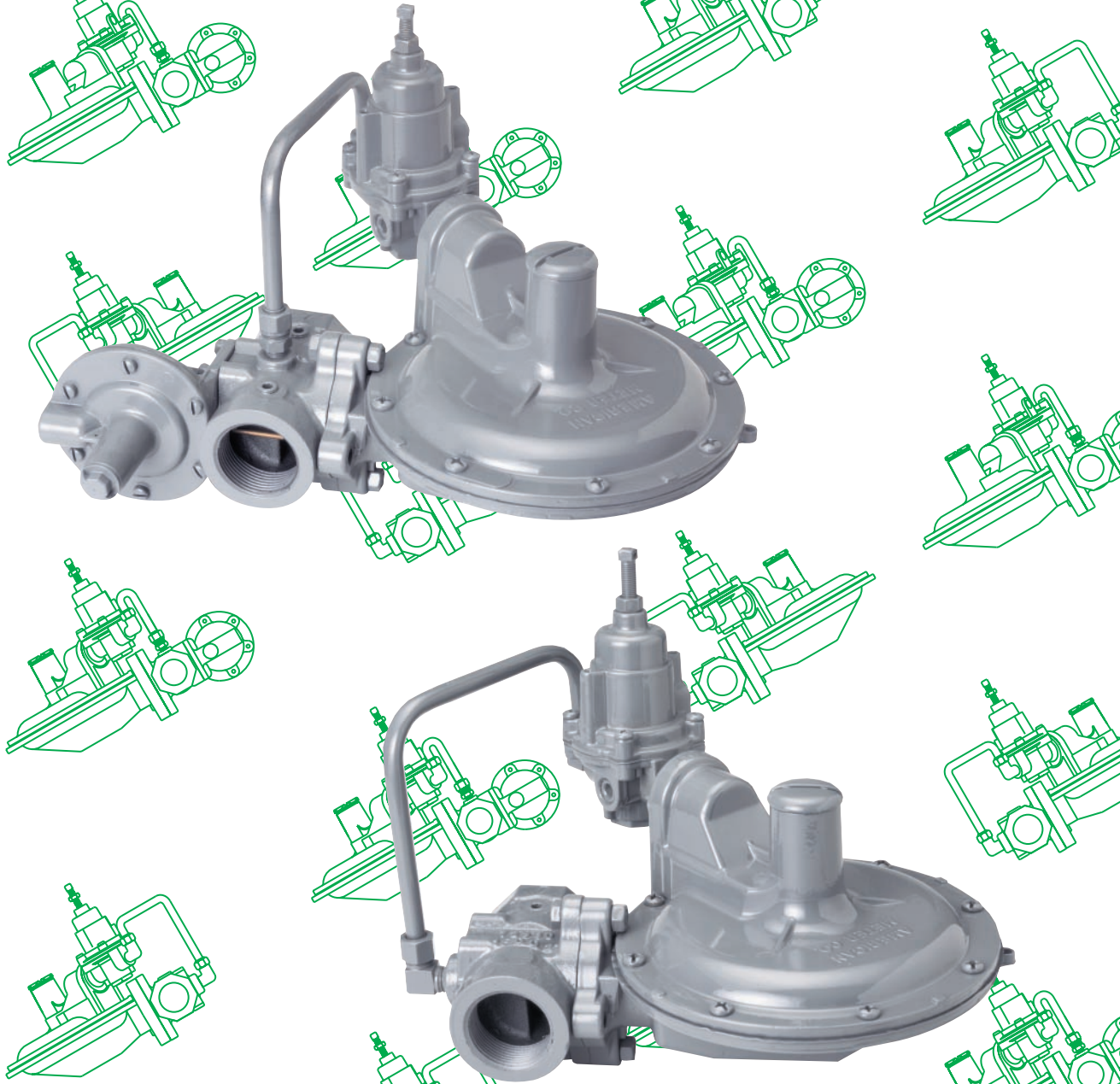

AMC Quality System
QMI is Accredited by:



ISO 9001 Certified
Certificate #006697



Dutch Council
for Accreditation



AMERICAN METER COMPANY

Measurement Engineers Since 1836

www.americanmeter.com

1800CPB2 Service Regulators

General Information

The American Meter Series 1800CPB2 pressure regulator is designed for natural gas applications and features a compact, lightweight design for fast, easy installation.

The 1800CPB2 regulator consists of a main regulator and a pilot regulator. It is a downstream bleed, pressure loaded regulator, designed to provide stability of operation for precise and constant outlet metering pressure control. The regulator is capable of handling varying inlet pressures up to 125 PSIG while controlling a set constant outlet pressure (1 to 30 PSIG) within $\pm 1\%$ of the absolute set pressure over a wide range of flow rates.

The main regulator is normally closed, furnished with one spring (for all outlet pressures) to close the regulator if loading pressure fails. The pilot regulator outlet line mounts to the main regulator vent and connection tubing brings the main regulator inlet pressure to the pilot regulator inlet.

The pilot regulator (one spring controls all outlet pressures from 1 PSIG to 30 PSIG) is used to load pressure on the diaphragm of the main regulator. Adjustment of the pilot regulator depends upon the inlet pressure and outlet pressure range desired. The pilot regulator using upstream pressure as its supply, reduces this pressure to a predetermined value and then loads the main regulator diaphragm. The loading pressure overcomes the force of the main regulator spring causing the main regulator to open.

Exclusive, 7 - Step Corrosion Protection

The protective finish on the Series 1800CPB2 regulators resists corrosive effects of weather and harsh environments better than any other in the industry. Each precision die cast aluminum regulator is treated-inside and out-with a special conversion coating that's part of an exclusive, 7-step finishing process. This coating greatly inhibits oxidation of the metal's surface that can eventually compromise the integrity of the metal. It also prevents finish paint from cracking and blistering.

A single coat polyester primer and the high solid polyurethane top coat provides a long-lasting protection to all exterior regulator surfaces. The American Meter conversion coating process meets all environmental protection regulations.

High Tensile Strength Valve Bodies

Each Series of 1800CPB2 regulator is equipped with a high tensile strength cast iron valve body and features extra heavy wall thickness. This provides maximum strength to withstand installation stresses without damage and prevents thread galling experienced with aluminum.

Series 1800CPB2 regulator valve bodies are treated with a 5-step metal finishing process. The treated metal is primer painted with a single coat polyester paint.

Available valve body sizes are: 3/4" x 3/4", 3/4" x 1", 3/4" x 1-1/4", 1" x 1", 1" x 1-1/4" and 1-1/4" x 1-1/4" NPT or BSP-TR.

Application

The 1800CPB2 regulator is designed for pressure reducing service requiring stability and metering accuracy. They are used on gas distribution systems as intermediate or low pressure regulators. They are also effective for large farm and commercial operations with widely varying inlet pressures up to 125 PSIG with accurate control of outlet pressures between 1 PSIG and 30 PSIG. 1800CPB2 regulators are excellent for use with American Meter large capacity meters as well as with American Meter domestic meters.

Model 1883CPB2 is equipped with overpressure shut-off (OPSO) that provides protection against downstream overpressure (see page 6).

The 1800CPB2 regulator will accurately control the metering pressure to a constant value, thus the pressure correction factor becomes a constant factor for a given metering pressure. The pressure-corrected volume equals meter volume multiplied by the pressure factor constant.

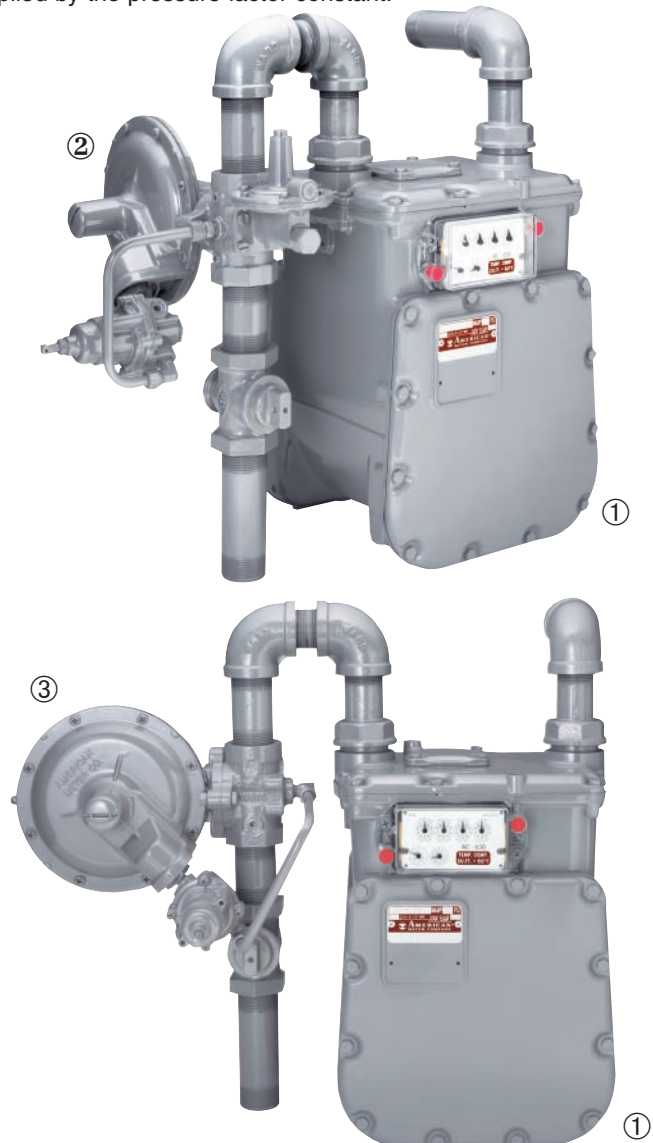

① AC-630 Aluminumcase Meter ② 1883CPB2 Regulator
③ 1800CPB2 Regulator

1800CPB2 Service Regulators

Fixed Factor Measurement

Fixed factor measurement is the measurement of gas at a controlled elevated pressure without the use of an automatic correcting device to correct the volume for variations from base or contract pressure. The 1800CPB2 regulator provides accurately controlled, constant metering pressure for this application.

Volume of gas being metered at other than base pressure, must be corrected to base or contract conditions. The American Gas Association specifies that a cubic foot of gas at base conditions be defined as the quantity which occupies a volume of one cubic foot at a pressure of 14.73 PSIA and at a temperature of 60°F.

Therefore to determine the volume of gas at medium or high pressure, the volume must be corrected to base or contract pressure.

The correction factor to correct volume for pressure is determined from Boyle's Law:

$$\text{Volume Corrected} = \text{Volume Metered} \times \frac{\text{Metering Pressure} + \text{Atmospheric Pressure}}{\text{Base Pressure}}$$

Where temperature varies, American Meter recommends the 1800CPB2 regulator be used with a pressure compensating index for the desired metering pressure and with an American Meter temperature compensated meter to provide accurate flow measurement without subsequent calculations.

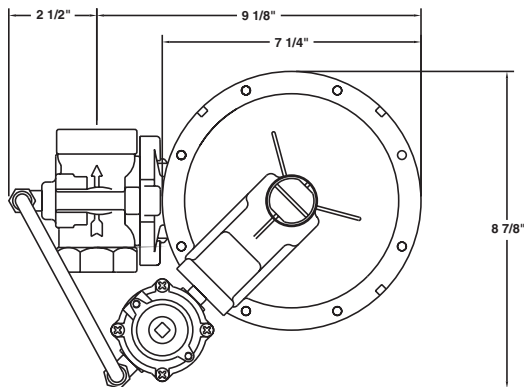

1800CPB2 Regulator

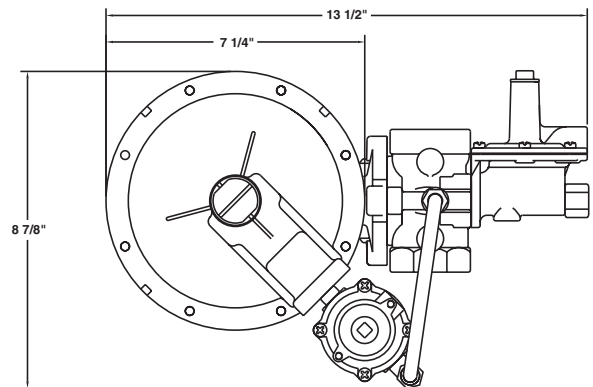

1883CPB2 Regulator

1800CPB2 Service Regulators

Capacity – 1 1/4" Model 1800CPB2 Regulator

1/8" x 3/16" Orifice

Outlet Pressure (PSIG)	Inlet Pressure (PSIG)							
	10	15	25	35	50	80**	100	125
1	350	450	600	750	1000	1450	1800	1900
2	350	450	600	750	1000	1450	1800	1900
5	300	400	600	750	1000	1450	1750	1900
10	–	350	600	750	1000	1450	1750	1900
20	–	–	450	700	1000	1400	1750	1900
30	–	–	–	550	950	1400	1750	1900

3/16" Orifice

Outlet Pressure (PSIG)	Inlet Pressure (PSIG)							
	10	15	25	35	50	80**	100	125
1	800	1050	1400	1750	2300	3400	4100	4200
2	800	1000	1400	1750	2300	3350	4100	4200
5	700	950	1350	1750	2250	3300	4000	4200
10	–	700	1350	1750	2250	3300	4000	4200
20	–	–	1000	1600	2250	3200	4000	4200
30	–	–	–	1000	2150	3200	3900	4200

1/4" Orifice

Outlet Pressure (PSIG)	Inlet Pressure (PSIG)							
	10	15	25	35	50	80**	100	125
1	1300	1700	2500	3150	4100	6100	6700	–
2	1300	1700	2500	3150	4100	6100	7200	–
5	1000	1500	2400	3100	4000	5850	7100	–
10	–	1200	2200	3050	3900	5850	7100	–
20	–	–	1400	2600	3900	5850	7100	–
30	–	–	–	1600	3400	5800	7100	–

1/4" Orifice

Outlet Pressure (PSIG)	Inlet Pressure (PSIG)							
	10	15	25	35	50	80**	100	125
1	1350	1750	2400	3000	3900	4500	4800	–
2	1300	1700	2400	3000	3900	5300	5500	–
5	1000	1450	2300	2950	3900	5600	6000	–
10	–	1100	2100	2900	3800	5600	6700	–
20	–	–	1300	2400	3600	5600	6700	–
30	–	–	–	1550	3150	5600	6700	–

5/16" Orifice

Outlet Pressure (PSIG)	Inlet Pressure (PSIG)							
	10	15	25	35	50**	80	100	125
1	2000	2600	3900	4900	6400	–	–	–
2	1900	2600	3800	4900	6300	–	–	–
5	1500	2300	3400	4600	6100	8500	–	–
10	–	1700	3200	4500	6000	8500	10200	–
20	–	–	2000	3800	5600	8500	10200	–
30	–	–	–	2400	4800	8000	10200	–

3/8" Orifice

Outlet Pressure (PSIG)	Inlet Pressure (PSIG)							
	10	15	25	35**	50	80	100	125
1	2300	3100	4400	5300	7150	–	–	–
2	2200	3000	4400	5300	7200	–	–	–
5	1700	2600	4050	5300	7150	–	–	–
10	–	2000	3600	5050	7050	–	–	–
20	–	–	2300	4200	6600	–	–	–
30	–	–	–	2800	6000	–	–	–

1/2" Orifice

Outlet Pressure (PSIG)	Inlet Pressure (PSIG)							
	10	15	25	35**	50	80	100	125
1	3200	4500	6350	7500	–	–	–	–
2	3200	4400	6300	7800	–	–	–	–
5	2600	4000	6100	7900	–	–	–	–
10	–	–	5500	7700	–	–	–	–
20	–	–	3600	6400	–	–	–	–
30	–	–	–	4150	–	–	–	–

Capacity – 1" Model 1800CPB2 Regulator

1/8" x 3/16" Orifice

Outlet Pressure (PSIG)	Inlet Pressure (PSIG)							
	10	15	25	35	50	80**	100	125
1	400	450	600	800	1000	1500	1800	1900
2	350	450	600	800	1000	1500	1800	1900
5	300	450	600	800	1000	1500	1800	1900
10	–	375	600	800	1000	1500	1800	1900
20	–	–	450	750	1000	1500	1800	1900
30	–	–	–	500	950	1500	1800	1900

3/16" Orifice

Outlet Pressure (PSIG)	Inlet Pressure (PSIG)							
	10	15	25	35	50	80**	100	125
1	800	1000	1250	1650	2200	3200	3800	–
2	800	1000	1350	1700	2200	3200	3800	–
5	700	950	1350	1700	2200	3200	3800	–
10	–	800	1300	1700	2200	3200	3800	4000
20	–	–	1000	1600	2200	3200	3800	4000
30	–	–	–	1100	2050	3200	3800	4000

1/4" Orifice

Outlet Pressure (PSIG)	Inlet Pressure (PSIG)							
	10	15	25	35	50	80**	100	125
1	1350	1750	2400	3000	3900	4500	4800	–
2	1300	1700	2400	3000	3900	5300	5500	–
5	1000	1450	2300	2950	3900	5600	6000	–
10	–	1100	2100	2900	3800	5600	6700	–
20	–	–	1300	2400	3600	5600	6700	–
30	–	–	–	1550	3150	5600	6700	–

5/16" Orifice

Outlet Pressure (PSIG)	Inlet Pressure (PSIG)							
	10	15	25	35	50**	80	100	125
1	1850	2500	3500	4000	4200	4500	–	–
2	1750	2400	3500	4300	5000	5500	–	–
5	1400	1950	3250	4200	5500	6600	7200	–
10	–	1500	2900	4000	5500	7000	7600	–
20	–	–	1800	3200	4900	7500	9000	–
30	–	–	–	1950	4300	7300	9000	–

3/8" Orifice

Outlet Pressure (PSIG)	Inlet Pressure (PSIG)							
	10	15	25	35**	50	80	100	125
1	2100	2800	3700	4000	4450	4900	–	–
2	2200	2600	3400	4200	4700	5350	–	–
5	1750	2500	3600	4600	5000	7300	–	–
10	–	1500	3400	4900	6100	7800	–	–
20	–	–	2200	4100	6000	8800	–	–
30	–	–	–	2650	5400	7300	–	–

1/2" Orifice

Outlet Pressure (PSIG)	Inlet Pressure (PSIG)							
	10	15	25	35**	50	80	100	125
1	2900	3350	4200	4200	–	–	–	–
2	3000	3400	4400	4900	–	–	–	–
5	2400	3000	4200	4950	–	–	–	–
10	–	2400	4300	5350	–	–	–	–
20	–	–	3000	5400	–	–	–	–
30	–	–	–	3600	–	–	–	–

1800CPB2 Service Regulators

Capacity – 3/4" Model 1800CPB2 Regulator 1/8" x 3/16" Orifice

Outlet Pressure (PSIG)	Inlet Pressure (PSIG)							
	10	15	25	35	50	80**	100	125
1	375	450	600	775	1000	1450	1800	1900
2	375	450	600	775	1000	1500	1800	1900
5	350	450	600	800	1000	1500	1800	1900
10	–	400	600	800	1000	1500	1800	1900
20	–	–	500	750	1000	1500	1800	1900
30	–	–	–	600	1000	1500	1800	1900

3/16" Orifice

Outlet Pressure (PSIG)	Inlet Pressure (PSIG)							
	10	15	25	35	50	80**	100	125
1	800	1000	1350	1700	2200	2500	2000	–
2	750	1000	1350	1700	2200	2650	2700	–
5	700	950	1300	1700	2200	3200	3100	–
10	–	800	1300	1700	2200	3200	3900	4000
20	–	–	1000	1550	2200	3200	3900	4000
30	–	–	–	1100	2100	3200	3850	4000

1/4" Orifice

Outlet Pressure (PSIG)	Inlet Pressure (PSIG)							
	10	15	25	35	50	80**	100	125
1	1200	1600	2200	2800	2800	2500	2000	–
2	1200	1500	2200	2800	2800	2800	2500	–
5	1000	1400	2100	2600	2800	3300	3500	–
10	–	1100	2000	2600	3200	3800	4200	–
20	–	–	1300	2300	3500	4600	5100	–
30	–	–	–	1550	3000	5300	5900	–

5/16" Orifice

Outlet Pressure (PSIG)	Inlet Pressure (PSIG)							
	10	15	25	35	50**	80	100	125
1	1500	2000	2200	2300	2350	–	–	–
2	1400	1900	2000	2400	2600	3100	3100	–
5	1400	2000	2500	2900	3150	3450	3600	–
10	–	1600	2700	3300	3700	4100	4200	–
20	–	–	1900	3300	4300	5300	5600	–
30	–	–	–	2300	4500	6100	6400	–

3/8" Orifice

Outlet Pressure (PSIG)	Inlet Pressure (PSIG)							
	10	15	25	35**	50	80	100	125
1	1600	1900	2000	2100	2300	–	–	–
2	1600	1900	2200	2500	2600	2900	–	–
5	1600	2100	2600	2800	3250	3450	–	–
10	–	1800	2800	3300	3600	4100	–	–
20	–	–	2250	3400	4500	5300	–	–
30	–	–	–	2600	4750	6500	–	–

1/2" Orifice

Outlet Pressure (PSIG)	Inlet Pressure (PSIG)							
	10	15	25	35**	50	80	100	125
1	1700	1900	2300	2400	–	–	–	–
2	1500	2150	2200	2300	–	–	–	–
5	2000	2400	2800	3100	3200	–	–	–
10	–	2400	3200	3500	3750	–	–	–
20	–	–	3000	4100	4600	–	–	–
30	–	–	–	3500	5300	–	–	–

Note: Capacity figures shown represent the capability of the regulator when installed with **adequately sized downstream piping.**

The following table may be used as a guide in sizing downstream piping:

Pipe Size	Maximum Flow SCFH
3/4"	2,000
1"	3,000
1 1/4"	6,000
1 1/2"	9,000

** Set Inlet Pressure for all outlet pressures
Set Flow 200 SCFH of 0.60 Specific Gravity

At given outlet pressure setting, the outlet pressure is controlled to $\pm 1\%$ absolute outlet pressure over full range of inlet pressure shown.

Typical Performance Data

Model No.: 1800CPB2 Set Flow: 200 S.C.F.H.
 Set Pressure P1: 80 PSIG Test Medium: 0.60 SP. GR. Gas
 Set Pressure P2: 5 PSIG 14.7 PSIA–60°F

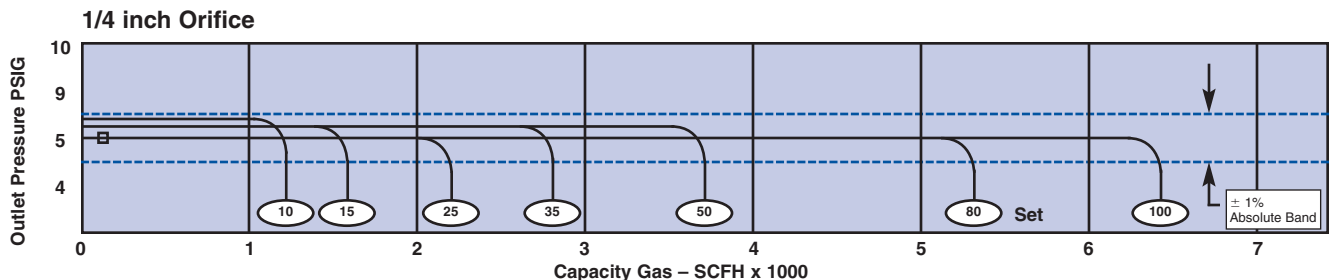

Overpressure Shut-off Regulators

Overpressure Shut-off (OPSO) Regulators

Model 1883CPB2 regulators are compact units designed to regulate line pressure and to provide protection against any downstream overpressure.

Rugged, Compact OPSO - Operates independently. The OPSO will shut-off the gas supply in the event of a serious downstream pressure build-up.

Adjustable Overpressure Shut-off - Pressure is adjustable via the overpressure shut-off adjustment screw to settings from 5 to 15 PSIG and 15 to 40 PSIG depending on spring selected.

How The OPSO Operates

When the outlet pressure exceeds the OPSO set point, the pressure under the OPSO diaphragm (A) compresses the pressure spring (B) forcing the diaphragm stem (E) upwards and releasing plunger (D). This permits the shut-off spring (F) to force the shut-off disc (G) against the back side of the special double ended orifice.

Shut-off Assembly

72978G097

72978G096

Adjustable Trip Point Range

5 to 15 PSIG

15 to 40 PSIG

Note: The OPSO setting is preset at the factory to the desired trip point.

To reset the OPSO, shut-off gas supply and depressurize the regulator system, unscrew cap (C), pull back the plunger (D) until the diaphragm stem (E) repositions.

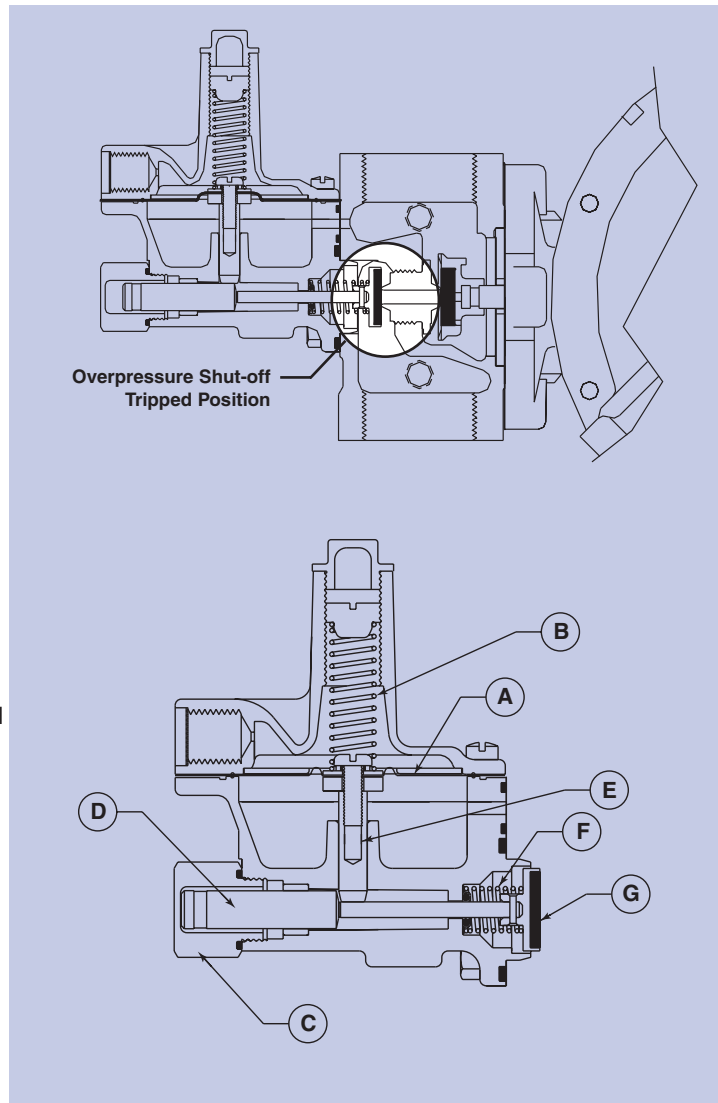

1800CPB2 Service Regulators

Full Open Regulator Relief Capacity

For sizing downstream relief valves, use the following formulas to determine the regulator full open capacity:

For critical flow rates

$$Q = 0.5 C \times \frac{P_1}{\sqrt{G}}$$

For sub-critical flows

$$Q = C \frac{\sqrt{P_2 h}}{\sqrt{G}}$$

Key:

- Q = Maximum capacity of regulator
- C = Orifice constant, see table
- P₁ = Inlet absolute pressure (PSIA)
- P₂ = Outlet absolute pressure (PSIA)
- h = Differential pressure (P₁ - P₂)
- G = Specific gravity of gas

Orifice	C
1/8"	25
1/8" x 3/16"	25
3/16"	57
1/4"	98
5/16"	149
3/8"	208
1/2"	353
9/16"	421

1800CPB2 Service Regulators

Regulator Assembly Positions For 1800CPB2 Models

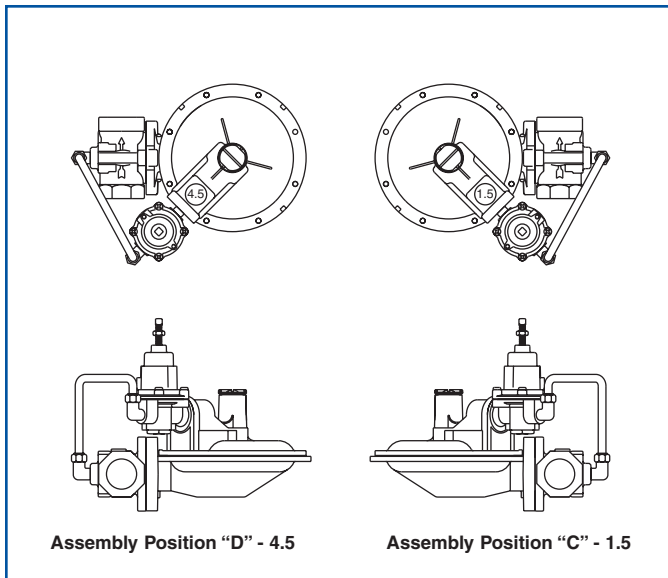

Regulator Assembly Positions For 1883CPB2 Models

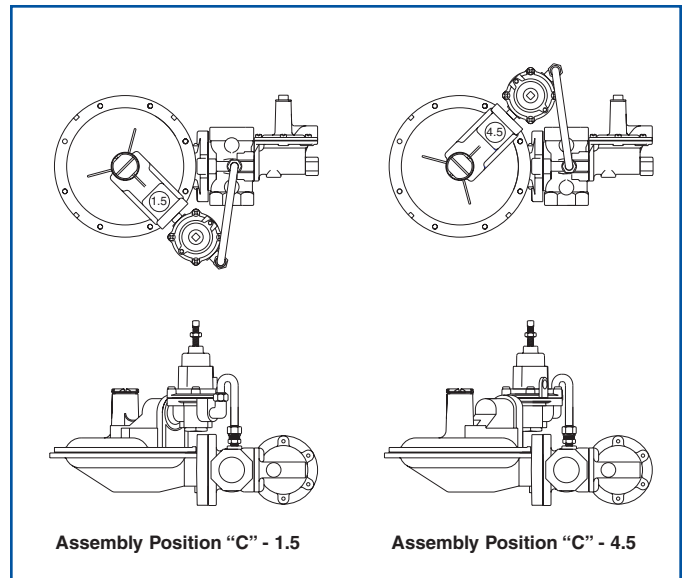

Regulator Descriptions

Model Number	Description
1800CPB2	Pilot loading regulator, non-relieving
1883CPB2	Pilot loading regulator, non-relieving with overpressure shutoff (OPSO)

Orifice Sizes

Orifice Size	Part Number	
	Standard	w/ OPSO
1/8" x 3/16"	72494P030	72751P020
3/16"	72494P020	72751P011
1/4"	72494P021	72751P012
5/16"	72494P022	72751P013
3/8"	72494P023	72751P014
1/2"	72494P025	72751P016

Maximum Recommended Inlet Pressure

Orifice Size	Inlet Pressure (PSIG)
1/8" x 3/16"	125
3/16"	125
1/4"	100
5/16"	100
3/8"	80
1/2"	50

See pages 4 and 5 for capacity performance for each orifice size.

1800CPB2 Service Regulators

Construction

Lower Diaphragm Case - Precision die cast aluminum with a exclusive 7-step advanced conversion coating, single coat polyester primer and High Solid Polyurethane Top Coat.

Top Assembly - Precision die cast aluminum with a exclusive 7-step advanced conversion coating, single coat polyester primer and High Solid Polyurethane Top Coat.

Valve Body - Cast grey iron, undercoated, single coat polyester primer and High Solid Polyurethane Top Coat, (Rotates in 90 degree increments).

Closing Spring - Steel, Zinc plated and yellow chromate. Color coded for identification.

Diaphragm Plate - Steel, terne plated.

Seat Disc - Buna-N.

Orifice - Super high strength, corrosion-resistant, aluminum.

Lever - Steel, zinc plated and yellow chromate.

Vent Screen - Stainless steel.

Seal Plug - Precision die cast aluminum.

Corrosion Protection

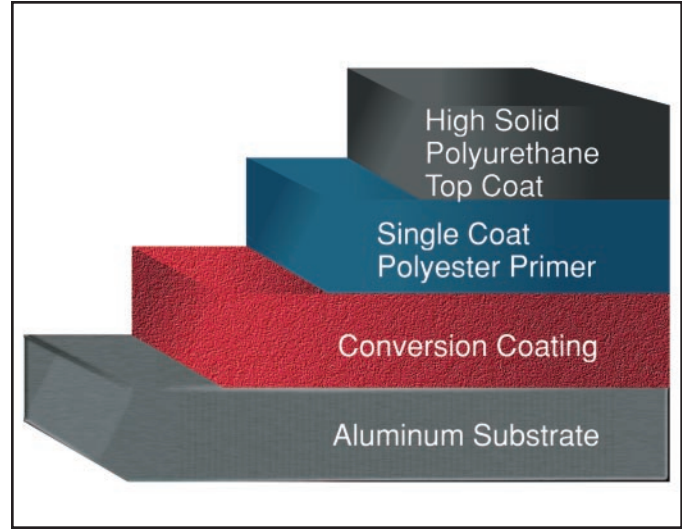

Ordering Information

- 1 Model number.
- 2 Size of inlet and outlet.
- 3 Inlet pressure, psi.
- 4 Outlet pressure, inches W.C. (or PSIG).
- 5 Flow, scfh.
- 6 Kind and specific gravity of gas.
- 7 Orifice size.
- 8 Regulator assembly position number.
- 9 OPSO shut-off set point. (1883CPB2 only)

Shipping Weight -

8.4 lbs/carton of one regulator

Regulator Pressure Rating

125 PSIG = Maximum recommended inlet pressure for normal service. Maximum recommended pressure may vary with orifice size.

175 PSIG = Maximum inlet pressure for abnormal or emergency service, without causing damage to regulator case.

30 PSIG = Maximum outlet pressure for normal service.

45 PSIG = Maximum outlet pressure which can be contained by pressure carrying components (no flange leakage to atmosphere). ***If regulator is subjected to these conditions, it should be removed from service.***

50 PSIG = Maximum outlet pressure for abnormal service without damage to internal components. ***If regulator is subjected to these conditions, it should be removed from service.***

Due to continuous development the information in this document is subject to change.



AMERICAN METER

300 Welsh Road, Building One • Horsham, PA 19044-2234 • USA • Tel: (215) 830-1800 • Fax: (215) 830-1890



CANADIAN METER

3037 Derry Road, West • Milton, Ontario L9T 2X6 • Canada • Tel: (905) 878-2361 • Fax: (905) 878-5758