

3000 Series Regulators

1-1/4", 1-1/2", 2", 3" & 4"
Instructions and Parts List

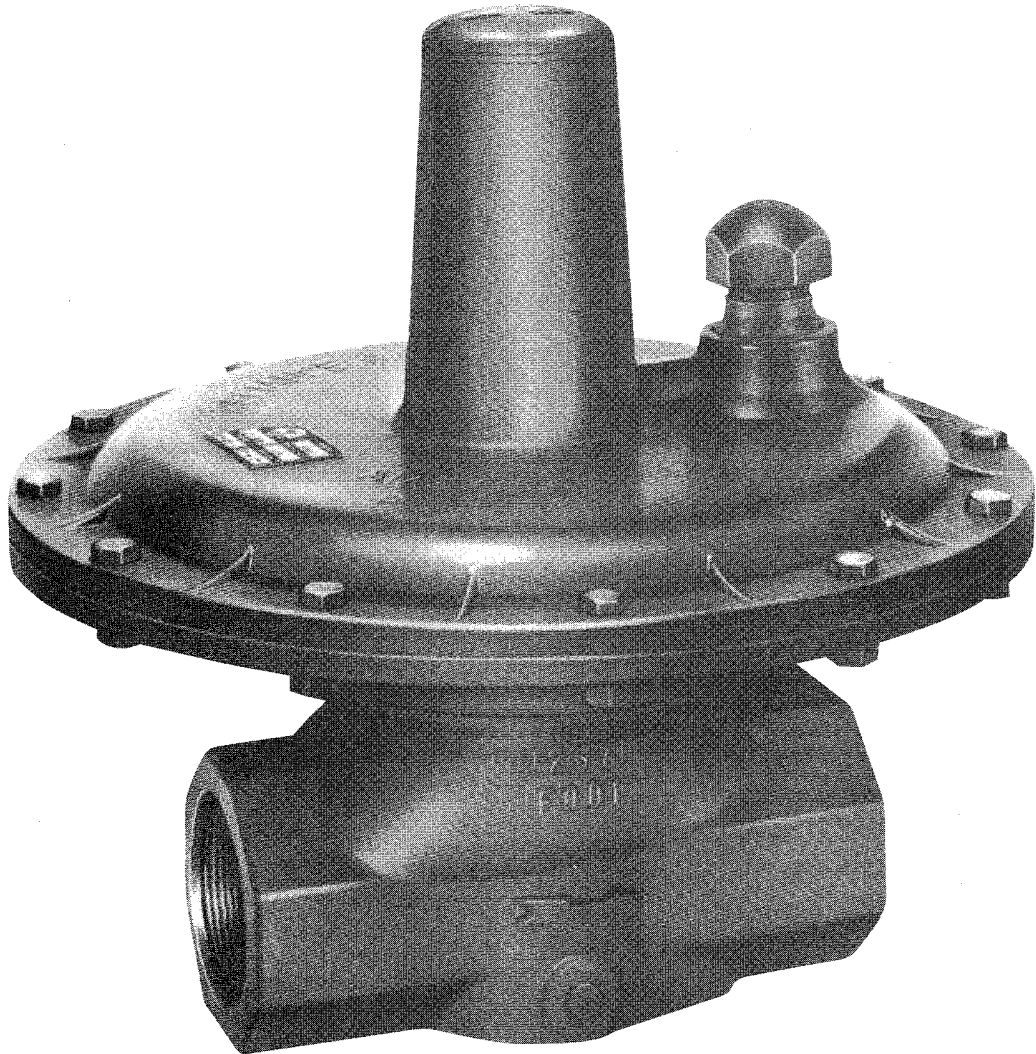

AMC Quality System

QMI is Accredited by:



ISO 9002 Certified



Dutch Council
for Accreditation



**AMERICAN
METER COMPANY**

Measurement Engineers Since 1836

INSTRUCTIONS: INDUSTRIAL REGULATOR SERIES 3000

GENERAL INFORMATION:

- Available Models – Standard Regulator (Model 3000)
 - Monitor Regulator (Model 3010)
- Available Sizes – 1-1/4", 1-1/2" – screwed connections
 - 2" screwed, 2" ANSI 125 lb. flange
 - 3" and 4" ANSI 125 lb. flange
- Maximum Inlet Pressure - 30 PSIG
- Outlet Pressure Range - 2" wc to 56" wc

PREPARATION

1. Install, operate, inspect and maintain the regulator as outlined in these instructions and in accordance with your company's policies and applicable federal, state and local codes and laws. Installation and service to be performed by qualified personnel only.

Failure to follow these instructions may result in damage to the regulator.

WARNING

Do not connect the inlet of the regulator to a normal pressure source higher than that recommended. Never connect the regulator outlet to the source of pressure. Observe the flow direction arrow on the valve head casting.

If inlet pressure can exceed the maximum regulator outlet pressure rating, some form of overpressure protection is required to prevent possible damage to the regulator and personal injury.

2. Check installation location for suitability. It is possible that physical changes have been made to the building site since the regulator and location were originally selected.
3. Examine regulator for shipping damage.
4. Check regulator and piping for dirt or other foreign matter which may have accumulated during shipment or handling.
5. Check data plate to determine if regulator is suitable for intended service.
6. Suitable stop valve(s) should be installed and should be conveniently located.
7. The top vent of the regulator must be unobstructed and must not be submerged in water at any time.
8. Filters are available from the manufacturer for applications where pipeline contaminants are suspected to be present.
9. Regulators may be used at temperatures between -20°F and +150°F (-30°C and 65°C).

INSTALLATION

1. Remove all shipping plugs.
2. Use good piping practice. Be sure piping and regulator are free of dirt, pipe dope and other debris. Apply pipe dope to male threads only.
3. The Series 3000 may be mounted in any position. Leave head room for removal of the diaphragm chamber to allow inspection of the valve seat. Make certain the regulator is piped up correctly with inlet pipe connection to the inlet connection and flow is in the direction as indicated by arrow located on body.
4. Turn gas on slowly. Outlet Stop Valves should be opened first. Do not overload the diaphragm with a sudden surge of inlet pressure.
5. Assure that there are no leaks and all connections are tight.
6. Pressure Adjustment:
 - (a) Turn gas off and depressurize the system.
 - (b) Install outlet pressure gauge. Remove seal plug, item (12),
Fig. 1 for Models 1-1/4", 1-1/2", 2" & 3" only.
 - (c) Turn gas on.
 - (d) Establish a low flow rate.

- (e) Turn pressure spring adjustment screw, on all models clockwise to increase outlet pressure or counterclockwise to decrease outlet pressure.
- (f) Establish a set pressure within the range limits of the pressure spring used.
- (g) To test for the regulator's ability to fully shut off (lock-up), shut off all flow downstream of the regulator. At lock-up, the outlet pressure will be somewhat higher than the set pressure. However, if the pressure continues to rise after (3) seconds, the regulator must be repaired. Observe for approximately 30 seconds.
- (h) When the set pressure has been properly adjusted and lock-up tested depressurize and remove gauges and lines.
- (i) Replace seal plug.
- (j) Pressurize – check all connections for leaks.

INSPECTION AND MAINTENANCE:

WARNING

If the regulator system develops a leak or vents gas, call a qualified gas serviceman promptly.

Inspection and maintenance of the 3000 regulator has been simplified for practical reasons. Access to the regulator is gained by removing the circular clamp ring, item (4), then lifting the entire regulator (less body) out of the line. A new working unit may be substituted while the one removed is being serviced. Repair parts are offered if maintenance of the regulator is required. Normal replacement parts are the seat disc, item (2), which can become pitted and worn and the Buna N or felt ring (3) which may collect moisture or particles of foreign matter.

Lock-up tests should be conducted periodically to check the valve seat disc and valve cage sealing surface condition. Inspection of the valve seat disc and valve cage may be performed in the field. Follow the instructions below. Care should be exercised to prevent foreign matter from entering the regulator.

Procedure for inspection and replacement of the valve seat disc and/or valve cage:

1. Shut off gas supply and depressurize the regulator system.
2. Remove the clamp ring, item (4), by loosening the clamp tension nut just enough to slip the ring over the joint. Let the ring rest on the regulator body.
3. Lift the diaphragm chamber and valve assembly vertically from the body. Visually inspect the seating edge of the valve cage, item (5) and the valve seat disc, item (2). Replace if damaged.
4. To remove the seat disc and/or cage, grip the valve stem, item (6), with an open-end wrench and remove the retaining nut (7), valve stem flapper (8) and balancing piston (9). When reassembling the valve cage and valve seat, make certain the balancing piston is centered on the shoulder under the seat disc retainer (10). When tightening the retaining nut, be careful not to distort the valve stem flapper.
5. Apply silicone grease sparingly to the O-ring (21) at the bottom of the valve cage. Assemble the diaphragm chamber to the regulator body, keeping the chamber vertical and allowing its own weight to seat the assembly. Do not rotate the chamber as this may distort the secondary diaphragm (11). Center clamp ring over body joint and tighten clamp tension nut.

INSTRUCTIONS: INDUSTRIAL REGULATOR SERIES 3000

REPLACING THE PRESSURE SPRING:

1-1/4" TO 3" MODELS

1. Shut off the gas supply and depressurize the regulator system. Remove the seal plug (12).
2. Unscrew pressure adjusting screw (1) with a screwdriver and remove the pressure adjusting screw completely.
3. Remove the pressure spring (13) and install a new pressure spring, centering the lower end of the spring in the spring guide (14).
4. Replace the pressure adjusting screw and turn adjusting screw to about mid-position.
5. Adjust the outlet set pressure as described above and replace the seal plug.

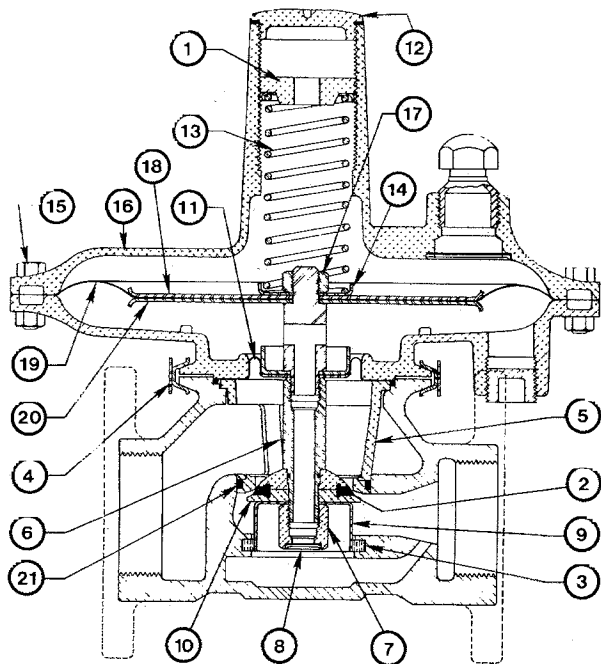

Figure 1

REPLACING THE PRESSURE SPRING:

(For 4" Model only)

1. To remove seal plug, first loosen adjusting screw lock nut, completely back off adjusting screw and then turn down approximately 1/8" (2 turns). Remove seal plug. Hold adjusting screw to prevent rotation while unscrewing seal plug. Replace pressure spring with lower end centered in spring guide.
2. To install seal plug assembly, position spring follower approximately 1/8" (2 turns) from shoulder on adjusting screw. Engage slot of spring follower with inner rib in regulator top and hold spring follower up against underside of threads in top while engaging seal plug. Hold adjusting screw to prevent rotation while screwing seal plug into position.

CAUTION

Regulators that have a pressure spring removed or replaced must have their set pressure established. If the pressure spring is different from that shown on the data plate, mark spring range on the regulator or on its tag, and cross out the old value.

REPLACING THE DIAPHRAGM

1. To replace the diaphragm assembly, first remove the spring, then the complete diaphragm chamber and valve assembly. Then remove the flange bolts (15) and lift off the upper diaphragm chamber (16). Remove the pressure spring. Grip the valve stem (6) with an open-end wrench and remove the diaphragm stem nut (17), spring guide, upper diaphragm plate (18) and the diaphragm (19). Do not remove the lower diaphragm plate (20).
2. Install the new diaphragm, the top diaphragm plate, spring guide and stem nut, being careful to align the diaphragm bolt holes with those in the body.
3. Place the upper diaphragm chamber over the diaphragm, with the vent in the proper position and install the bolts. Take care to prevent folds in the diaphragm between flanges. Install the range spring and adjusting screw.
4. Apply silicone grease sparingly to the O-ring at the bottom of valve cage and assemble the diaphragm chamber to the regulator body as previously described.
5. Adjust the outlet set pressure as described above and replace seal plug.

REPLACING THE FELT RING (2", 3", & 4" SIZES)

1. Remove the diaphragm chamber and valve cage assembly.
2. Remove and install a new balancing piston felt ring (3). The felt strip must be installed so that when placed in the groove, the side with the black identification stripes is facing toward the coupling ring flange, and the joining ends should face the inlet port. Care should be taken to insure that even contact is made between the felt ring and the balancing piston throughout their circumference, including the point where the ends of the felt ring meet.

Black identification stripes
(or letter "T")

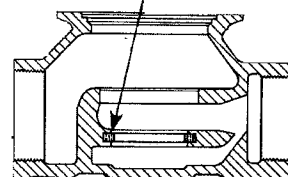

NOTE: When installing the Buna N balancing piston ring in the 1-1/4" & 1-1/2" sizes, insure that the letter T stamped on the ring faces upward.

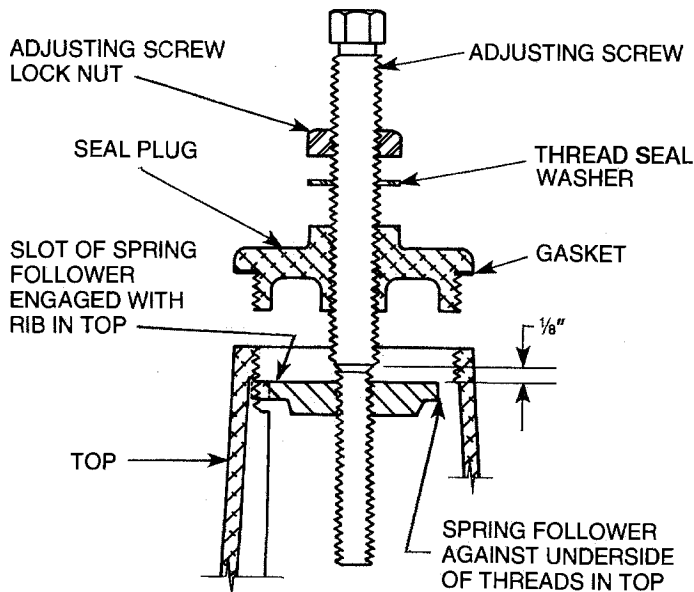

4" MODEL ONLY
PRESSURE SPRING REPLACEMENT

1-1/4" & 1-1/2" Model 3000 Industrial Regulator Assembly

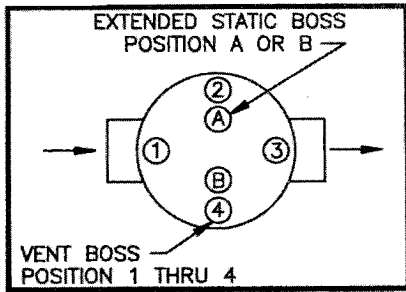

REGULATOR ASSEMBLY POSITIONS

NOTES:

- INSTALL BALANCING PISTON RING WITH "T" MARKING UP. JOINT CAN BE IN ANY POSITION

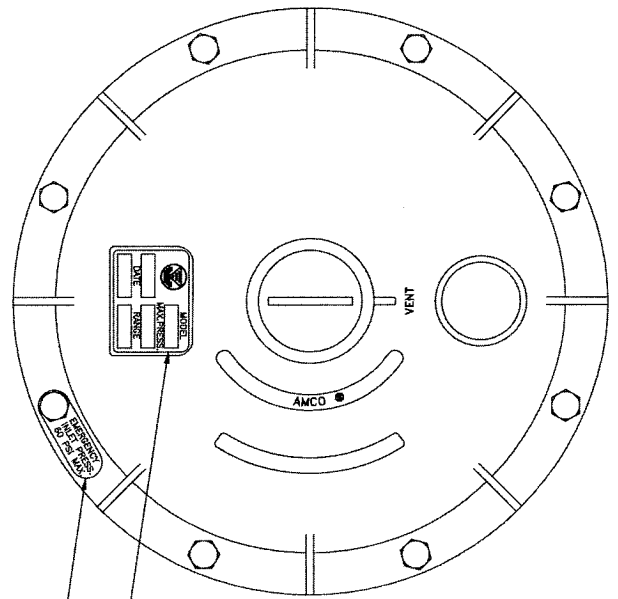

TOP VIEW

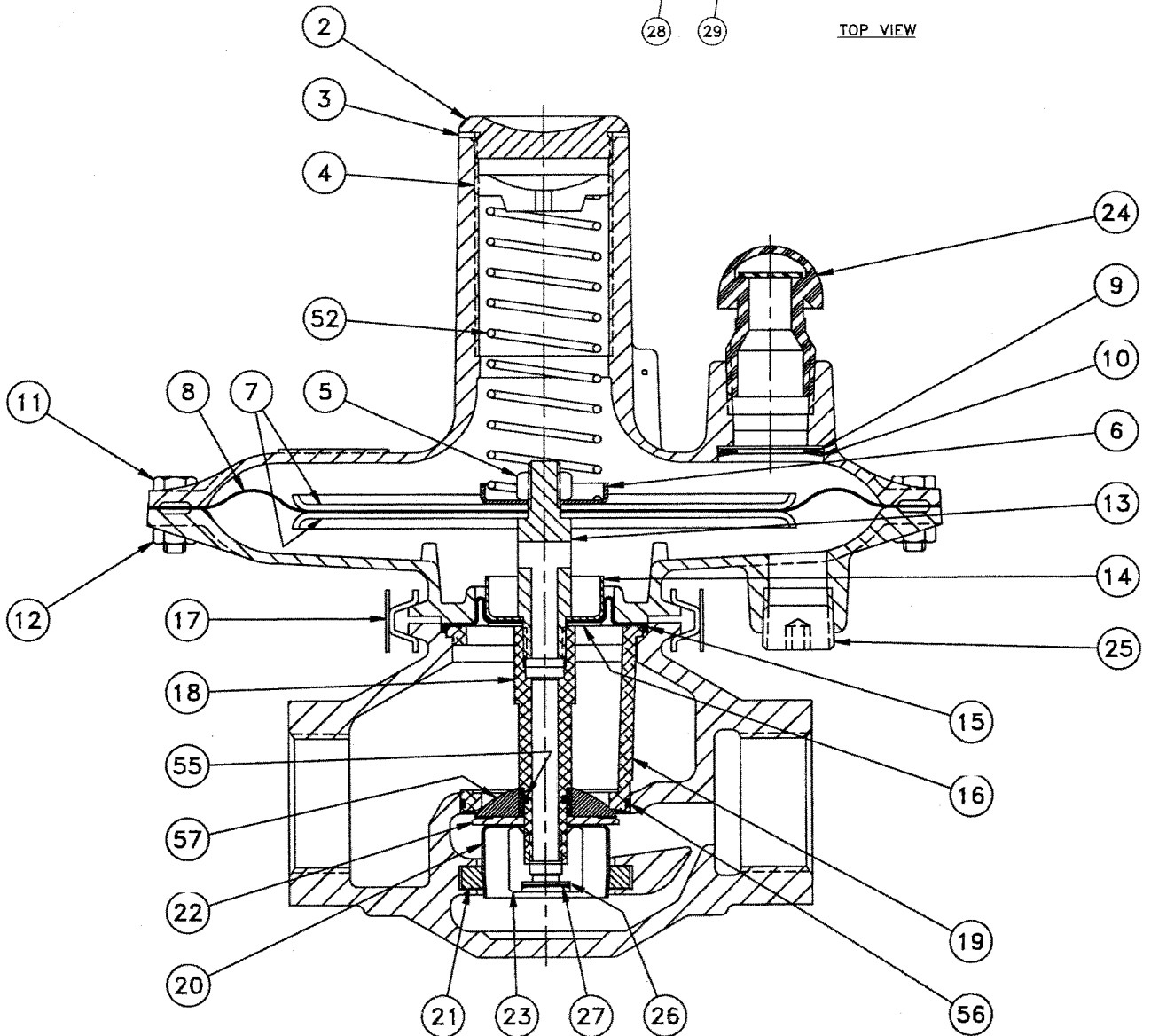

1-1/4" & 1-1/2" Model 3000 Industrial Regulator Assembly

Common Parts List

QTY	ITEM #	PART NAME	PART NO.	DESCRIPTION	MATERIAL
1	2	PLUG SEAL	73081P001		ALUMINUM
1	3	GASKET (SEAL PLUG)	70019P098		BUNA-N
1	4	PRESSURE ADJUSTING SCREW	73080P001		ALUMINUM
1	5	DIAPHRAGM STEM NUT	78020P005		ZINC PLATED STEEL
1	6	SPRING GUIDE	72272P004		ZINC PLATED STEEL
2	7	DIAPHRAGM PLATE	70012P057		ZINC PLATED STEEL
1	8	DIAPHRAGM	70014P169		BUNA-N
1	9	VENT FLAPPER	72163P017		BUNA-N
1	10	RETAINING RING (VENT FLAPPER)	78074P009		ZINC PLATED STEEL
8	11	HEX HEAD CAP SCREW	78001P004	1/4-28 X .75 LG.	ZINC PLATED STEEL
8	12	HEX NUT	22032P078	1/4-28	ZINC PLATED STEEL
1	13	DIAPHRAGM STEM	73029P001		ALUMINUM
1	14	SECONDARY DIAPHRAGM PLATE	73031P001	UPPER	ZINC PLATED STEEL
1	15	SECONDARY DIAPHRAGM	73034P001		BUNA-N
1	16	SECONDARY DIAPHRAGM PLATE	70176P034	LOWER	ZINC PLATED STEEL
1	17	BODY COUPLING	78134P001		ZINC PLATED STEEL
1	18	VALVE STEM	73030P001		ALUMINUM
1	19	VALVE CAGE	73027P001		ALUMINUM
1	20	BALANCING PISTON	73032P001		ZINC PLATED STEEL
1	21	BALANCING PISTON RING	74035P001		BUNA-N 80 DUROMETER
1	22	RETAINER	73033P001	LOWER	ALUMINUM
1	23	BALANCING PISTON RET. NUT	73288P001		ALUMINUM
1	24	VENT CAP	78069P004		PLASTIC
1	25	PIPE PLUG (LOWER CHAMBER)	78039P025	3/4" NPT	ZINC PLATED STEEL
1	26	VALVE STEM FLAPPER	72163P013		BUNA-N
1	27	RET. RING (VENT STEM FLAP)	78074P013		ZINC PLATED STEEL
1	28	TAG	78071P051		BRASS
1	29	LABEL	78482P002		ALUMINUM

Optional Parts List

QTY	ITEM #	PART NAME	PART NO.	DESCRIPTION	MATERIAL
1	52	PRESSURE SPRING	70157P033	1" - 3"	ZINC PLATED STEEL
			70157P034	3" - 7"	ZINC PLATED STEEL
			70157P035	7" - 14"	ZINC PLATED STEEL
			70157P036	14" - 28"	ZINC PLATED STEEL
			70157P037	1# - #2	ZINC PLATED STEEL
1	55	O-RING (VALVE STEM)	78037P005	STANDARD	BUNA-N
			78037P074		VITON-A
1	56	O-RING (VALVE CAGE)	78037P061	STANDARD	BUNA-N
			78037P081		VITON-A
1	57	VALVE SEAT DISC ASSEMBLY	73075G001	STANDARD	BUNA-N
			73075G002		VITON-A

Standard Spare Kits

PART NAME	PART NO.	DESCRIPTION
SPARE KIT	73913K001	INCLUDES IT# 3, 21, 26, 55, 56, 57
SPARE KIT	73913K002	INCLUDES IT# 3, 8, 9, 10, 11, 12, 15, 21, 26, 27, 55, 56, 57

1-1/4" & 1-1/2" Model 3010 Industrial Regulator Assembly

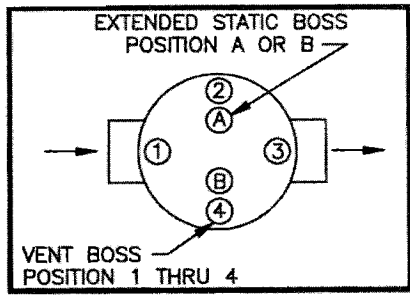

REGULATOR ASSEMBLY POSITIONS

NOTES:

- INSTALL BALANCING PISTON RING WITH "T" MARKING UP. JOINT CAN BE IN ANY POSITION

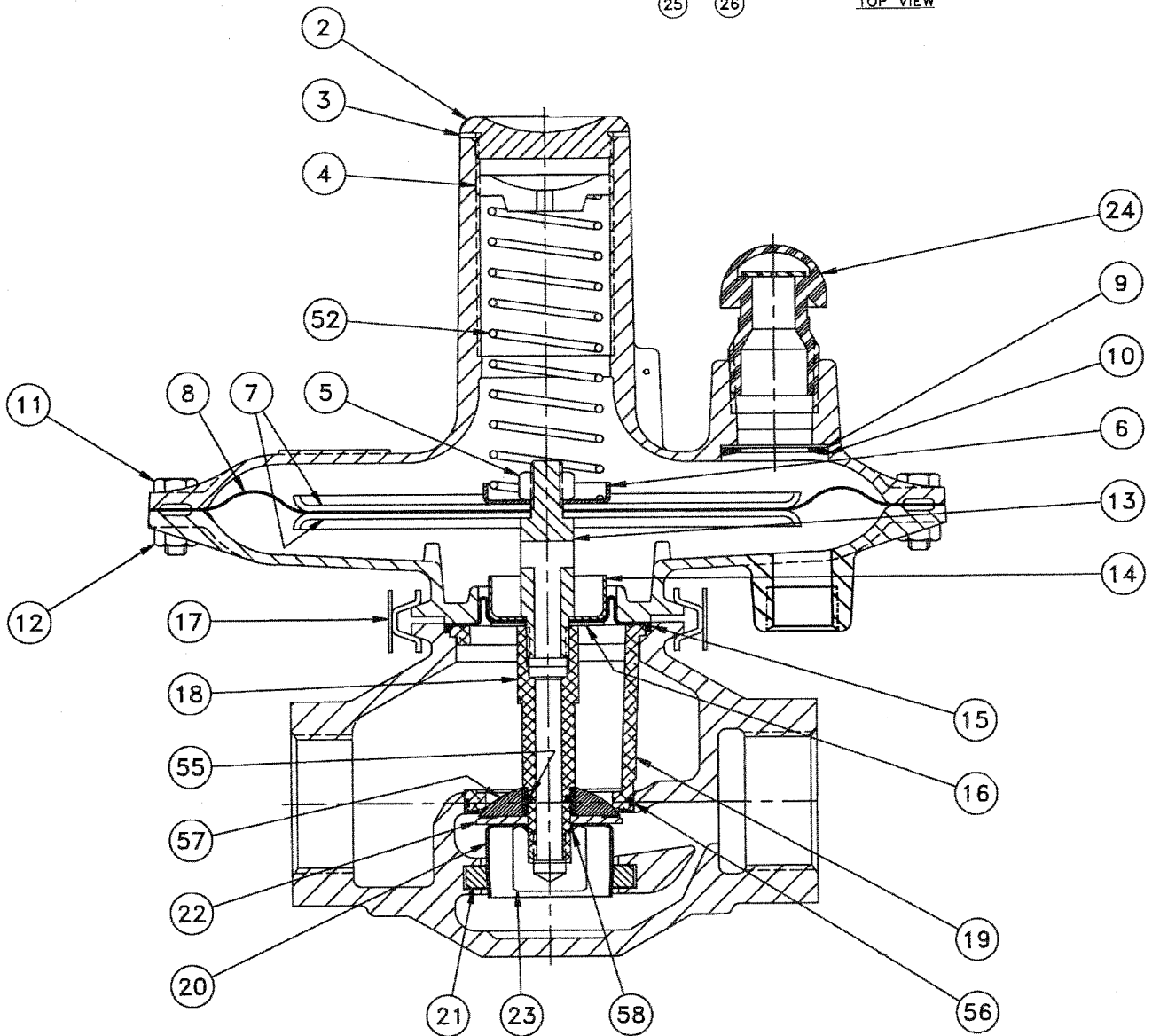
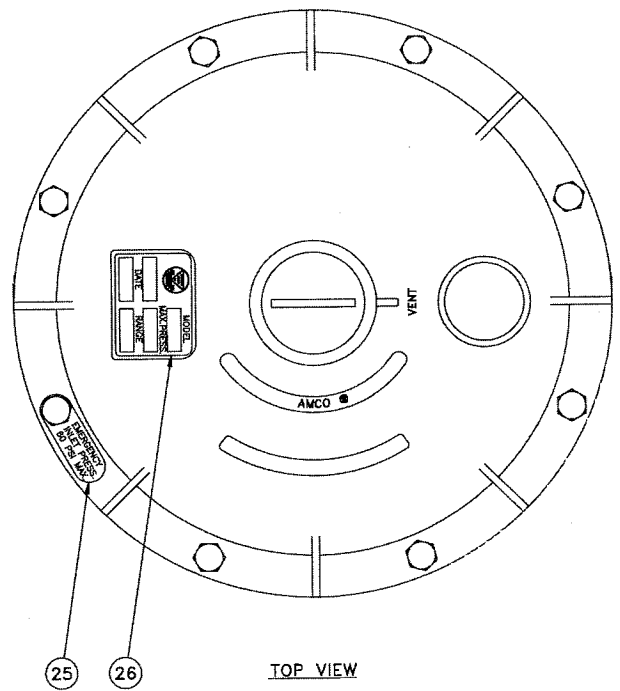

1-1/4" & 1-1/2" Model 3010 Industrial Regulator Assembly

Common Parts List

QTY	ITEM #	PART NAME	PART NO.	DESCRIPTION	MATERIAL
1	2	SEAL PLUG	73081P001		ALUMINUM
1	3	SEAL PLUG GASKET	70019P098		BUNA-N
1	4	PRESSURE ADJUSTING SCREW	73080P001		ALUMINUM
1	5	DIAPHRAGM STEM NUT	78020P005	1/2-20	ZINC PLATED STEEL
1	6	SPRING GUIDE	72272P004		ZINC PLATED STEEL
2	7	DIAPHRAGM PLATE	70012P057		ZINC PLATED STEEL
1	8	DIAPHRAGM	70014P169		BUNA-N
1	9	VENT FLAPPER	72163P017		BUNA-N
1	10	RETAINING RING (VENT FLAPPER)	78074P009		ZINC PLATED STEEL
8	11	HEX HEAD CAP SCREW	78001P004	1/4-28 X .75 LG.	ZINC PLATED STEEL
8	12	HEX NUT	22032P078	1/4-28	ZINC PLATED STEEL
1	13	DIAPHRAGM STEM	73029P001		ALUMINUM
1	14	SECONDARY DIAPHRAGM PLATE	73031P001	UPPER	ZINC PLATED STEEL
1	15	SECONDARY DIAPHRAGM	73034P001		BUNA-N
1	16	SECONDARY DIAPHRAGM PLATE	70176P034	LOWER	ZINC PLATED STEEL
1	17	BODY COUPLING	78134P001		ZINC PLATED STEEL
1	18	VALVE STEM	73030P001		ALUMINUM
1	19	VALVE CAGE	73027P001		ALUMINUM
1	20	BALANCING PISTON	73032P001		ZINC PLATED STEEL
1	21	BALANCING PISTON RING	74035P001		BUNA-N 80 DUROMETER
1	22	RETAINER	73033P001	LOWER	ALUMINUM
1	23	BALANCING PISTON RET. CAP	73156P001		ALUMINUM
1	24	VENT CAP	78069P004	1" NPT	PLASTIC
1	25	TAG	78071P051		BRASS
1	26	LABEL	78482P002		ALUMINUM

Optional Parts List

QTY	ITEM #	PART NAME	PART NO.	DESCRIPTION	MATERIAL
1	52	PRESSURE SPRING	70157P033	1" - 3"	ZINC PLATED STEEL
			70157P034	3" - 7"	ZINC PLATED STEEL
			70157P035	7" - 14"	ZINC PLATED STEEL
			70157P036	14" - 28"	ZINC PLATED STEEL
			70157P037	1# - #2	ZINC PLATED STEEL
1	55	O-RING (VALVE STEM)	78037P005	STANDARD	BUNA-N
			78037P074		VITON-A
1	56	O-RING (VALVE CAGE)	78037P061	STANDARD	BUNA-N
			78037P081		VITON-A
			73075G001	STANDARD	BUNA-N
1	57	VALVE DISC ASSEMBLY	73075G002		VITON-A
			73037P062	STANDARD	BUNA-N
1	58	O-RING (PISTON RET. CAP)	78037P082		VITON-A

Standard Spare Kits

PART NAME	PART NO.	DESCRIPTION
SPARE KIT	73913K001	INCLUDES IT# 3, 21, 26, 55, 56, 57
SPARE KIT	73913K002	INCLUDES IT# 3, 8, 9, 10, 11, 12, 15, 21, 55, 56, 57

2" Model 3000 Industrial Regulator Assembly

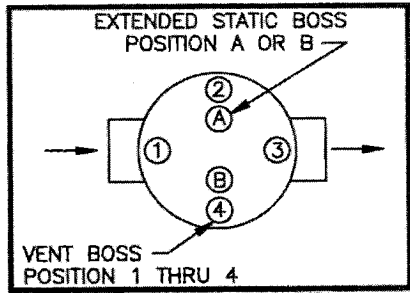

REGULATOR ASSEMBLY POSITIONS

NOTES:

- INSTALL FELT RING WITH BLACK STRIPES UP. JOINT TO BE LOCATED ON VALVE INLET SIDE.

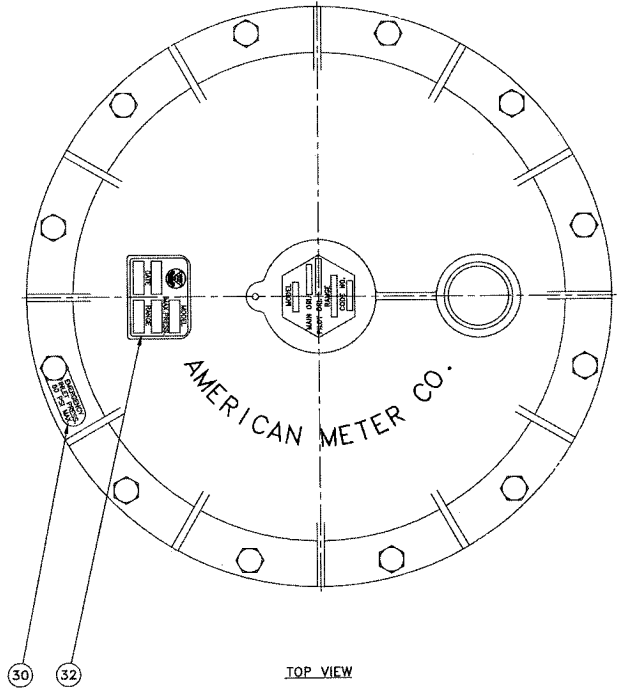

TOP VIEW

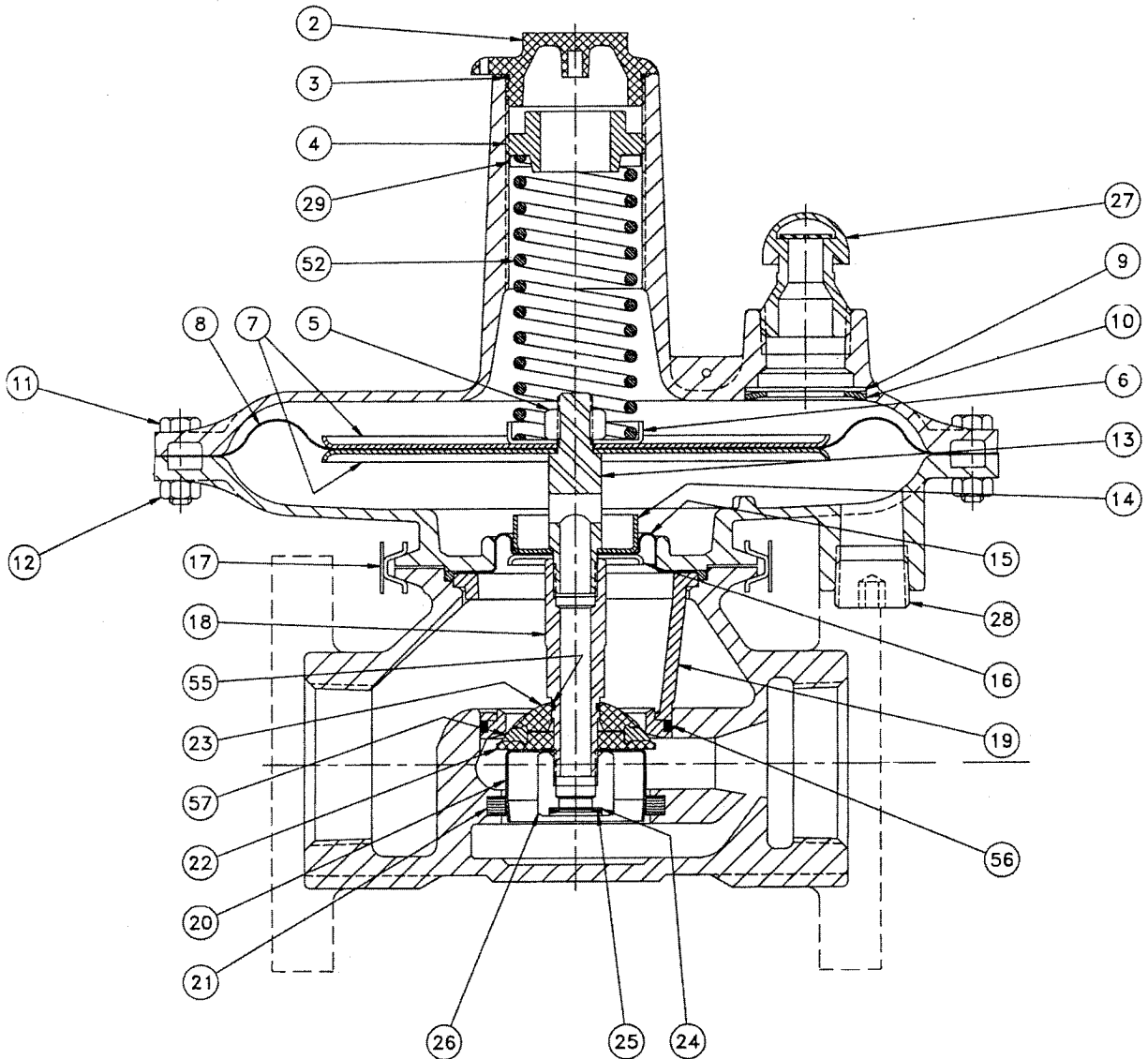

2" Model 3000 Industrial Regulator Assembly

Common Parts List

QTY	ITEM #	PART NAME	PART NO.	DESCRIPTION	MATERIAL
1	2	SEAL PLUG	70103P001		ALUMINUM
1	3	O-RING (SEAL PLUG)	42710P107	UNIF #133	BUNA-N
1	4	PRESSURE ADJUSTING SCREW	73183P001		ALUMINUM
1	5	DIAPHRAGM STEM NUT	78020P008	1/2-20	ZINC PLATED STEEL
1	6	SPRING GUIDE	70012P038		ZINC PLATED STEEL
2	7	DIAPHRAGM PLATE	70012P046		ZINC PLATED STEEL
1	8	DIAPHRAGM	70014P156		BUNA-N
1	9	VENT FLAPPER	72770P001		BUNA-N
1	10	RETAINING RING (VENT FLAPPER)	92943P118		ZINC PLATED STEEL
12	11	HEX HEAD CAP SCREW	78001P032	5/16-24 X 1.06 LG.	ZINC PLATED STEEL
12	12	HEX NUT	78020P003	5/16-24	ZINC PLATED STEEL
1	13	DIAPHRAGM STEM	72694P001		ALUMINUM
1	14	SECONDARY DIAPHRAGM PLATE	72689P001	UPPER	ZINC PLATED STEEL
1	15	SECONDARY DIAPHRAGM	72688P001		BUNA-N
1	16	SECONDARY DIAPHRAGM PLATE	70012P049	LOWER	ZINC PLATED STEEL
1	17	BODY COUPLING	78134P002		ZINC PLATED STEEL
1	18	VALVE STEM	72687P001		ALUMINUM
1	19	VALVE CAGE ASSEMBLY	73524G001		ALUMINUM
1	20	BALANCING PISTON	72695P001		ZINC PLATED STEEL
1	21	FELT RING	72699P001		FELT
1	22	SEAT DISC RETAINER	72959P001	LOWER	ALUMINUM
1	23	SEAT DISC RETAINER	72960P001	UPPER	ALUMINUM
1	24	VALVE STEM FLAPPER	72163P011		BUNA-N
1	25	RET. RING (VALVE STEM FLAP)	78074P024		ZINC PLATED STEEL
1	26	BALANCING PISTON RET. NUT	73286P001	BALANCING PISTON	ALUMINUM
1	27	VENT CAP	78069P005	1" NPT	PLASTIC
1	28	PIPE PLUG (LOWER CHAMBER)	78039P011	3/4" NPT	ZINC PLATED STEEL
1	29	SPRING FOLLOWER	73261P001		ZINC PLATED STEEL
1	30	TAG	78071P051		BRASS
1	31	INSTRUCTION TAG	73790P001	NOT SHOWN	
1	32	LABEL	78482P002		ALUMINUM

Optional Parts List

QTY	ITEM #	PART NAME	PART NO.	DESCRIPTION	MATERIAL
1	52	PRESSURE SPRING	72157P025	1" - 3"	ZINC PLATED STEEL
			70157P027	3" - 7"	ZINC PLATED STEEL
			70157P006	7" - 14"	ZINC PLATED STEEL
			70157P017	14" - 28"	ZINC PLATED STEEL
			70157P024	#1 - #2	ZINC PLATED STEEL
1	55	O-RING (VALVE STEM)	78037P054	STANDARD	BUNA-N
			78037P079		VITON-A
1	56	O-RING (VALVE CAGE)	78037P040	STANDARD	BUNA-N
			78037P076		VITON-A
1	57	VALVE SEAT DISC	72696P001	STANDARD	BUNA-N
			72696P002		VITON-A

Standard Spare Kits

PART NAME	PART NO.	DESCRIPTION
SPARE KIT	73913K003	INCLUDES IT# 3, 21, 24, 55, 56, 57
SPARE KIT	73913K004	INCLUDES IT# 3, 8, 9, 10, 11, 12, 15, 21, 24, 25, 55, 56, 57

2" Model 3010 Industrial Regulator Assembly

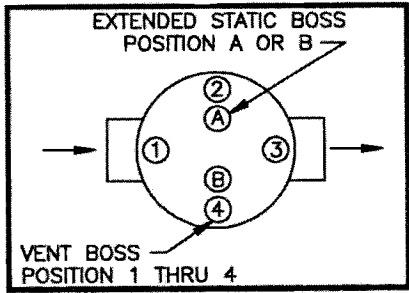

REGULATOR ASSEMBLY POSITIONS

NOTES:

- INSTALL FELT RING WITH BLACK STRIPES UP. JOINT TO BE LOCATED ON VALVE INLET SIDE.

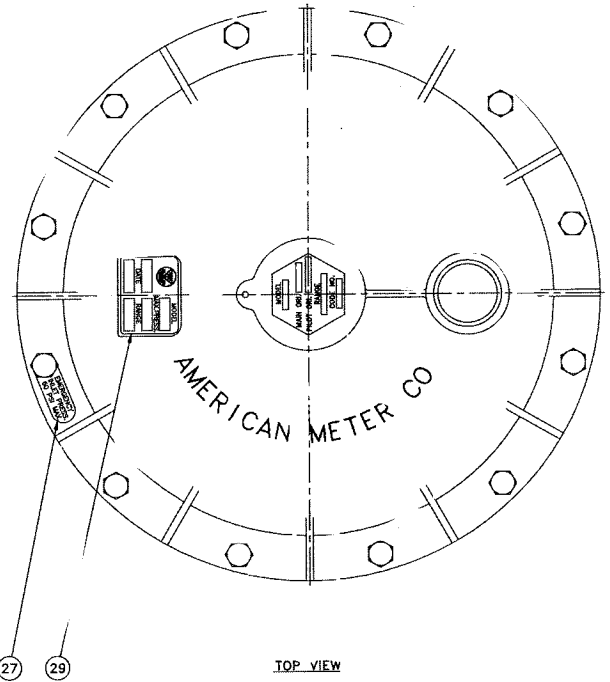

TOP VIEW

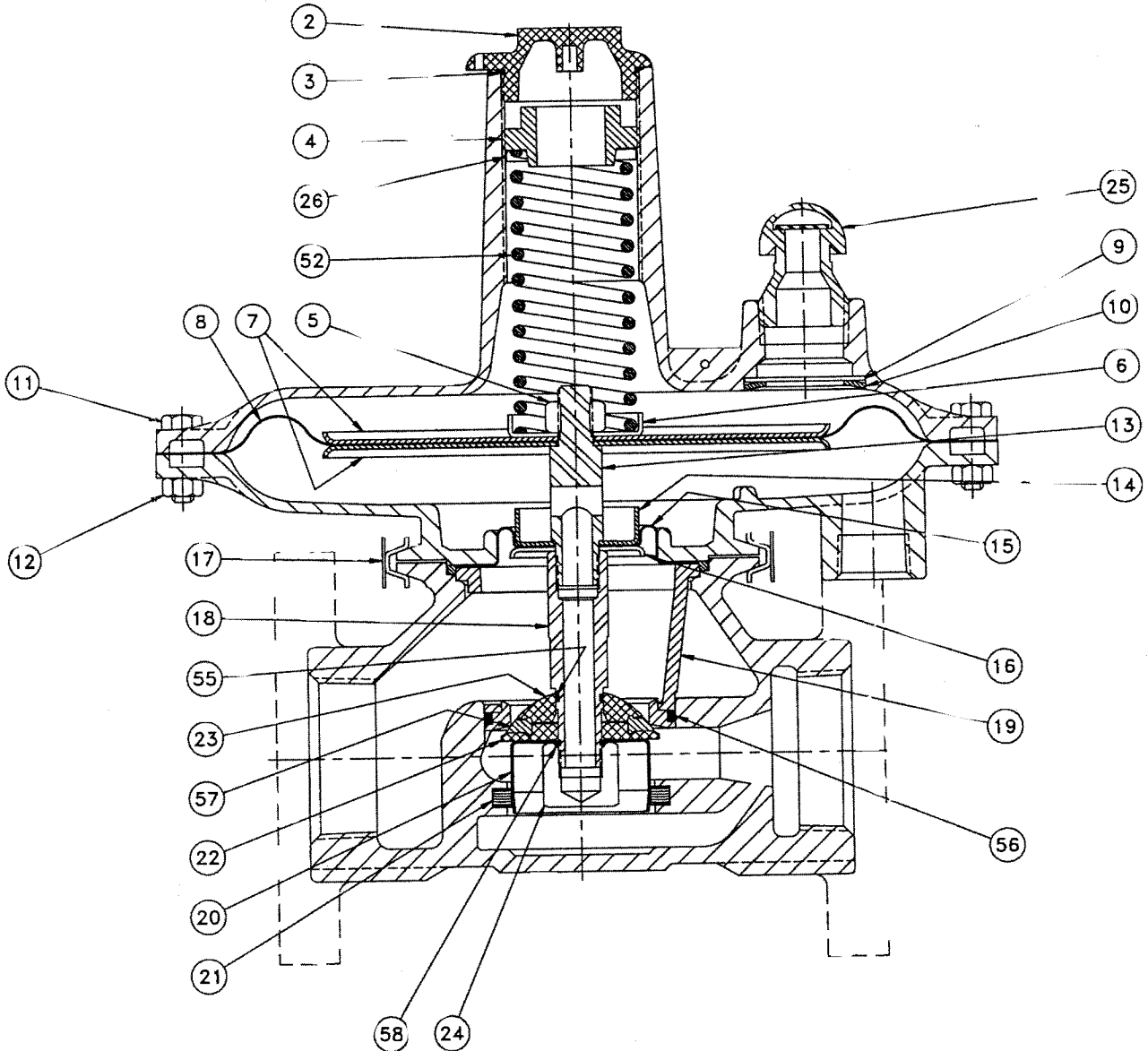

2" Model 3010 Industrial Regulator Assembly

Common Parts List

QTY	ITEM #	PART NAME	PART NO.	DESCRIPTION	MATERIAL
1	2	SEAL PLUG	70103P001		ALUMINUM
1	3	O-RING (SEAL PLUG)	42710P107	UNIF #133	BUNA-N
1	4	PRESSURE ADJUSTING SCREW	73183P001		ALUMINUM
1	5	DIAPHRAGM STEM NUT	78020P008	1/2-20	ZINC PLATED STEEL
1	6	SPRING GUIDE	70012P038		ZINC PLATED STEEL
2	7	DIAPHRAGM PLATE	70012P046		ZINC PLATED STEEL
1	8	DIAPHRAGM	70014P156		BUNA-N
1	9	VENT FLAPPER	72770P001		BUNA-N
1	10	RETAINING RING (VENT FLAPPER)	92943P118		ZINC PLATED STEEL
12	11	HEX HEAD CAP SCREW	78001P032	5/16-24 X 1.06 LG.	ZINC PLATED STEEL
12	12	HEX NUT	78020P003	5/16-24	ZINC PLATED STEEL
1	13	DIAPHRAGM STEM	72694P001		ALUMINUM
1	14	SECONDARY DIAPHRAGM PLATE	72689P001	UPPER	ZINC PLATED STEEL
1	15	SECONDARY DIAPHRAGM	72688P001		BUNA-N
1	16	SECONDARY DIAPHRAGM PLATE	70012P049	LOWER	ZINC PLATED STEEL
1	17	BODY COUPLING	78134P002		ZINC PLATED STEEL
1	18	VALVE STEM	72687P001		ALUMINUM
1	19	VALVE CAGE ASSEMBLY	73524G001		ALUMINUM
1	20	BALANCING PISTON	72695P001		ZINC PLATED STEEL
1	21	FELT RING	72699P001		FELT
1	22	SEAT DISC RETAINER	72959P001	LOWER	ALUMINUM
1	23	SEAT DISC RETAINER	72960P001	UPPER	ALUMINUM
1	24	BALANCING PISTON RET. CAP	72966P001		ALUMINUM
1	25	VENT CAP	78069P005	1" NPT	PLASTIC
1	26	SPRING FOLLOWER	73261P001		ZINC PLATED STEEL
1	27	TAG	78071P051		BRASS
1	28	INSTRUCTION TAG	73790P001	NOT SHOWN	
1	29	LABEL	78482P002		ALUMINUM

Optional Parts List

QTY	ITEM #	PART NAME	PART NO.	DESCRIPTION	MATERIAL
1	52	PRESSURE SPRING	72157P025	1" - 3"	ZINC PLATED STEEL
			70157P027	3" - 7"	ZINC PLATED STEEL
			70157P006	7" - 14"	ZINC PLATED STEEL
			70157P017	14" - 28"	ZINC PLATED STEEL
			70157P024	#1 - #2	ZINC PLATED STEEL
1	55	O-RING (VALVE STEM)	78037P054	STANDARD	BUNA-N
			78037P079		VITON-A
1	56	O-RING (VALVE CAGE)	78037P040	STANDARD	BUNA-N
			78037P076		VITON-A
1	57	VALVE SEAT DISC	72696P001	STANDARD	BUNA-N
			72696P002		VITON-A
1	58	O-RING (PISTON CAP)	78037P037	STANDARD	BUNA-N
			78037P085		VITON-A

Standard Spare Kits

PART NAME	PART NO.	DESCRIPTION
SPARE KIT	73913K003	INCLUDES IT# 3, 21, 55, 56, 57
SPARE KIT	73913K004	INCLUDES IT# 3, 8, 9, 10, 11, 12, 15, 21, 55, 56, 57

3" Model 3000 Industrial Regulator Assembly

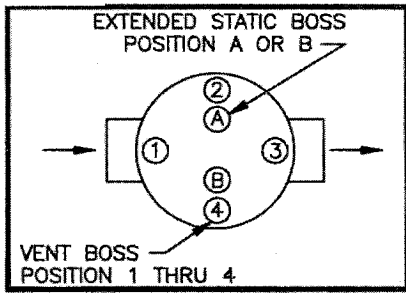

REGULATOR ASSEMBLY POSITIONS

NOTES:

- INSTALL FELT RING WITH BLACK STRIPES UP. JOINT TO BE LOCATED ON VALVE INLET SIDE.

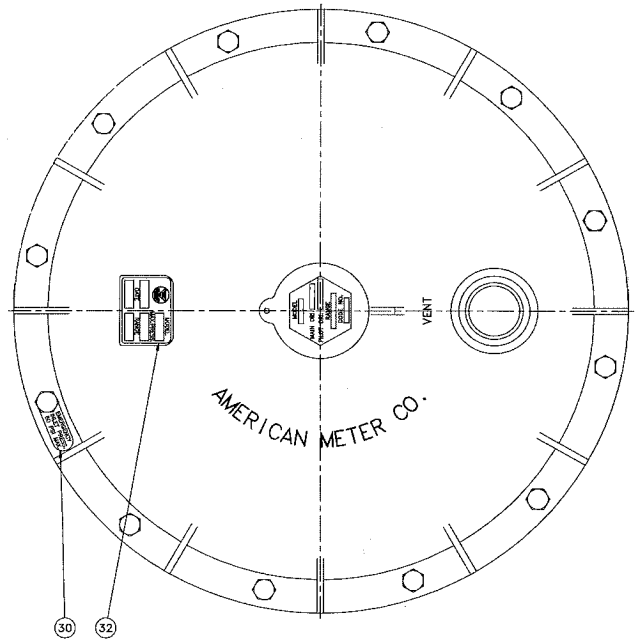

TOP VIEW

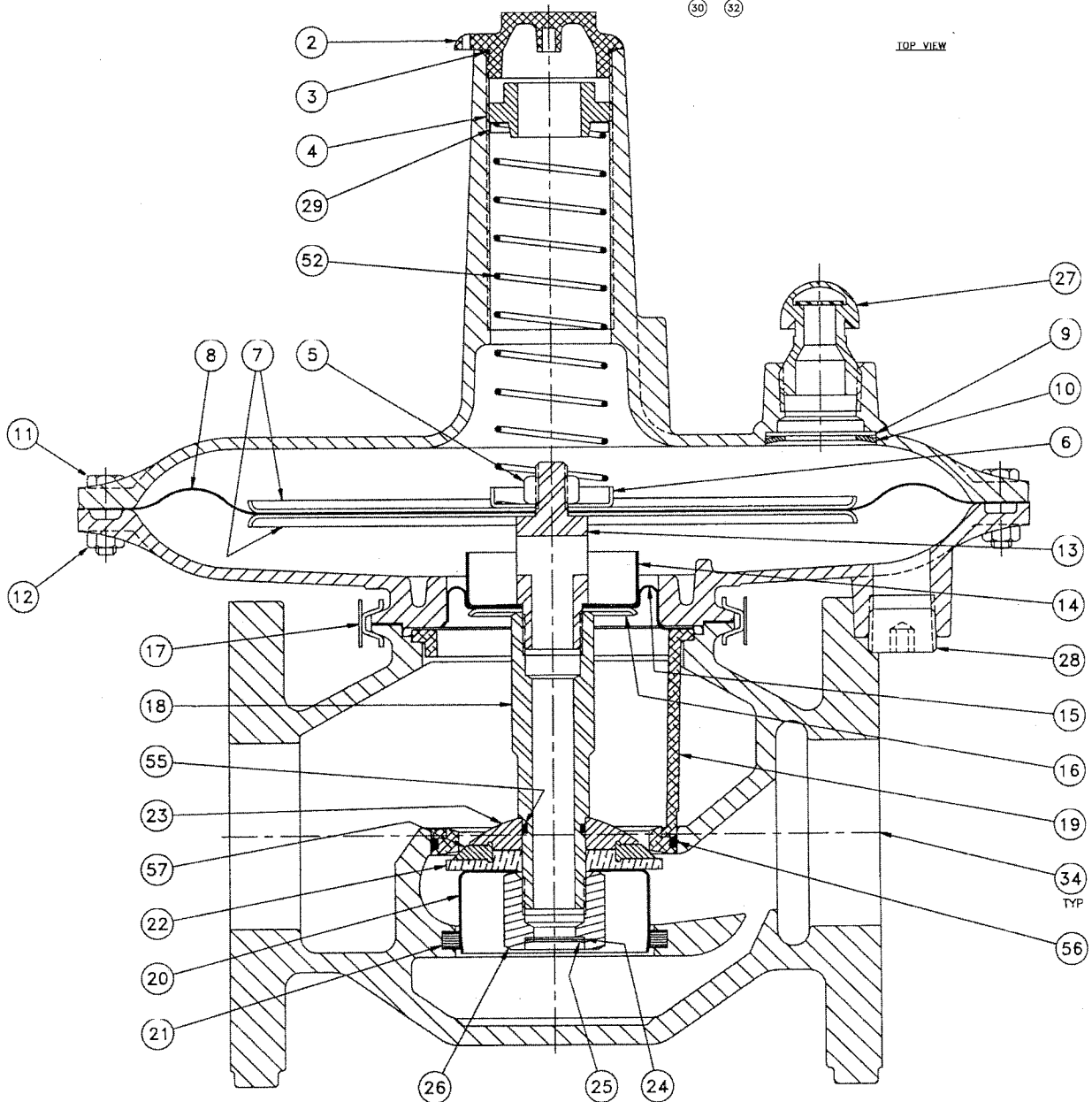

3" Model 3000 Industrial Regulator Assembly

Common Parts List

QTY	ITEM #	PART NAME	PART NO.	DESCRIPTION	MATERIAL
1	2	SEAL PLUG	70103P001		ALUMINUM
1	3	O-RING (SEAL PLUG)	42710P107	UNIF #133	BUNA-N
1	4	PRESSURE ADJUSTING SCREW	73183P001		ALUMINUM
1	5	DIAPHRAGM STEM NUT	78020P008	1/2-20	ZINC PLATED STEEL
1	6	SPRING GUIDE	70012P038		ZINC PLATED STEEL
2	7	DIAPHRAGM PLATE	70012P033		ZINC PLATED STEEL
1	8	DIAPHRAGM	70014P179		BUNA-N
1	9	VENT FLAPPER	72770P001		BUNA-N
1	10	RETAINING RING (VENT FLAPPER)	92943P118		ZINC PLATED STEEL
12	11	HEX HEAD CAP SCREW	78001P032	5/16-24 X 1.06 LG.	ZINC PLATED STEEL
12	12	HEX NUT	78020P003	5/16-24	ZINC PLATED STEEL
1	13	DIAPHRAGM STEM	72976P001		ALUMINUM
1	14	SECONDARY DIAPHRAGM PLATE	72977P001	UPPER	ZINC PLATED STEEL
1	15	SECONDARY DIAPHRAGM	72968P001		BUNA-N
1	16	SECONDARY DIAPHRAGM PLATE	70012P048	LOWER	ZINC PLATED STEEL
1	17	BODY COUPLING	78134P003		ZINC PLATED STEEL
1	18	VALVE STEM	72973P001		ALUMINUM
1	19	VALVE CAGE ASSEMBLY	73524G002		ALUMINUM
1	20	BALANCING PISTON	72675P001		ZINC PLATED STEEL
1	21	FELT RING	72699P002		FELT
1	22	SEAT DISC RETAINER	72974P001	LOWER	ALUMINUM
1	23	SEAT DISC RETAINER	72970P001	UPPER	ALUMINUM
1	24	VALVE STEM FLAPPER	72163P012		BUNA-N
1	25	RET. RING (VALVE STEM FLAP)	78074P025		ZINC PLATED STEEL
1	26	BALANCING PISTON RET. NUT	73287P001		ALUMINUM
1	27	VENT CAP	78069P005	1" NPT	PLASTIC
1	28	PIPE PLUG (LOWER CHAMBER)	78039P011	3/4" NPT	ZINC PLATED STEEL
1	29	SPRING FOLLOWER	73261P001		ZINC PLATED STEEL
1	30	TAG	78071P051		BRASS
1	31	INSTRUCTION TAG	73790P001	NOT SHOWN	
1	32	LABEL	78482P002		ALUMINUM

Optional Parts List

QTY	ITEM #	PART NAME	PART NO.	DESCRIPTION	MATERIAL
1	52	PRESSURE SPRING	72157P028	1" - 3"	ZINC PLATED STEEL
			70157P029	3" - 7"	ZINC PLATED STEEL
			70157P030	7" - 14"	ZINC PLATED STEEL
			70157P031	14" - 28"	ZINC PLATED STEEL
			70157P032	#1 - #2	ZINC PLATED STEEL
1	55	O-RING (VALVE STEM)	78037P044	STANDARD	BUNA-N
			78037P077		VITON-A
1	56	O-RING (VALVE CAGE)	78037P045	STANDARD	BUNA-N
			78037P078		VITON-A
1	57	VALVE SEAT DISC	72696P001	STANDARD	BUNA-N
			72696P002		VITON-A

Standard Spare Kits

PART NAME	PART NO.	DESCRIPTION
SPARE KIT	73913K005	INCLUDES IT# 3, 21, 24, 55, 56, 57
SPARE KIT	73913K006	INCLUDES IT# 3, 8, 9, 10, 11, 12, 15, 21, 24, 25, 55, 56, 57

3" Model 3010 Industrial Regulator Assembly

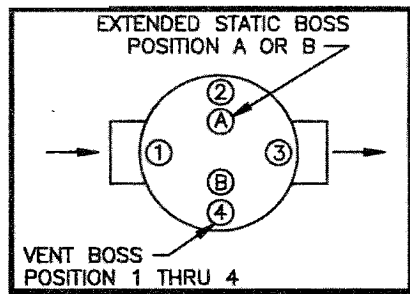

REGULATOR ASSEMBLY POSITIONS

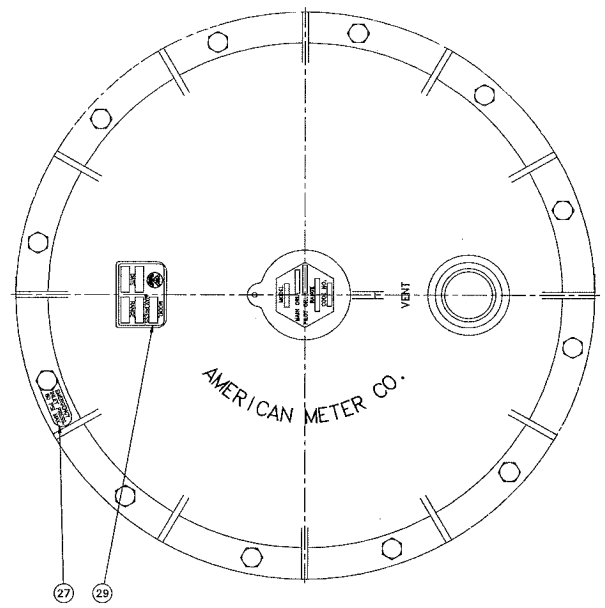

TOP VIEW

NOTES:

- INSTALL FELT RING WITH BLACK STRIPES UP. JOINT TO BE LOCATED ON VALVE INLET SIDE.

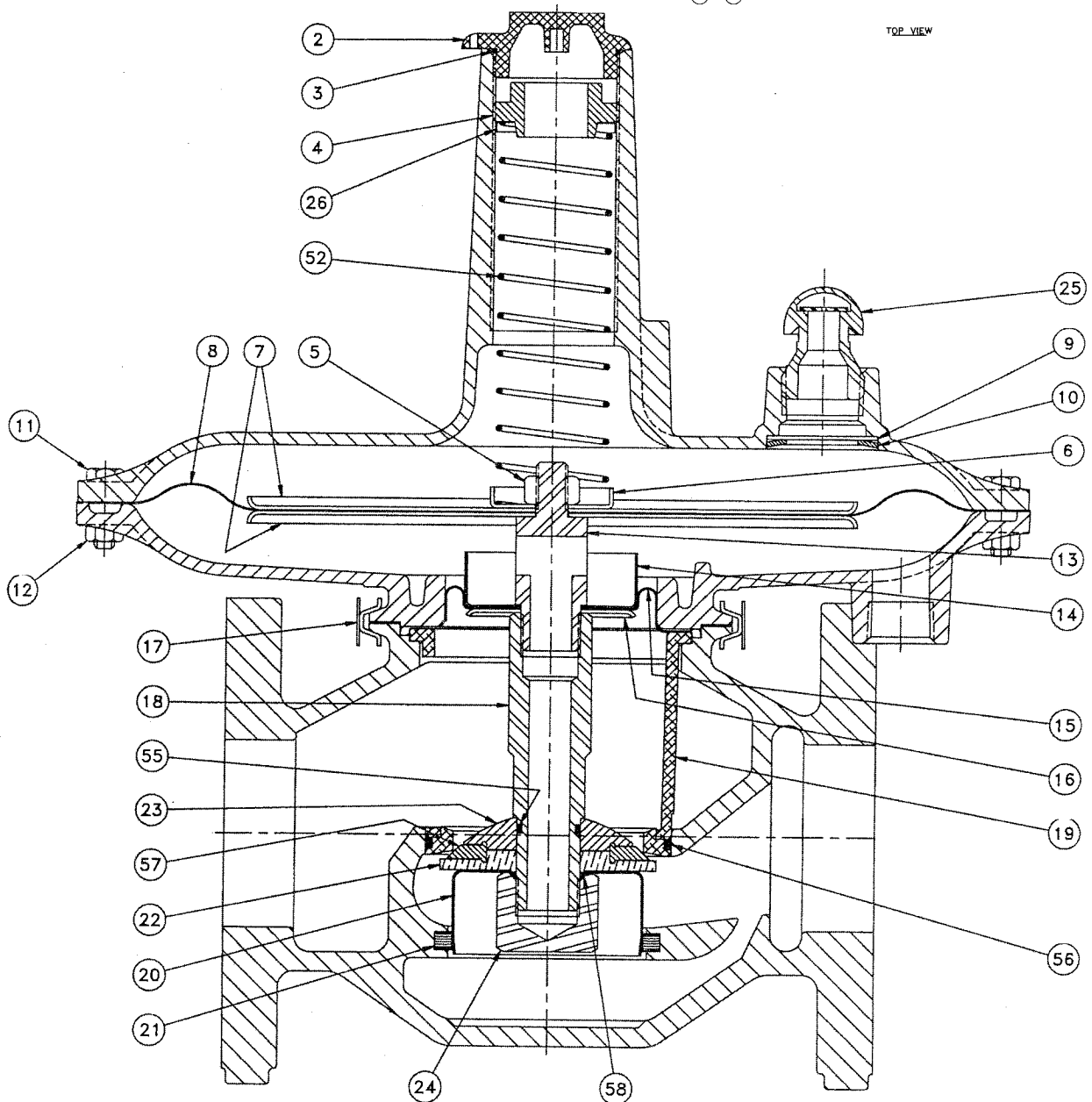

3" Model 3010 Industrial Regulator Assembly

Common Parts List

QTY	ITEM #	PART NAME	PART NO.	DESCRIPTION	MATERIAL
1	2	SEAL PLUG	70103P001		ALUMINUM
1	3	O-RING (SEAL PLUG)	42710P107	UNIF #133	BUNA-N
1	4	PRESSURE ADJUSTING SCREW	73183P001		ALUMINUM
1	5	DIAPHRAGM STEM NUT	78020P008	1/2-20	ZINC PLATED STEEL
1	6	SPRING GUIDE	70012P038		ZINC PLATED STEEL
2	7	DIAPHRAGM PLATE	70012P033		ZINC PLATED STEEL
1	8	DIAPHRAGM	70014P179		BUNA-N
1	9	VENT FLAPPER	72770P001		BUNA-N
1	10	RETAINING RING (VENT FLAPPER)	92943P118		ZINC PLATED STEEL
12	11	HEX HEAD CAP SCREW	78001P032	5/16-24 X 1.06 LG.	ZINC PLATED STEEL
12	12	HEX NUT	78020P003	5/16-24	ZINC PLATED STEEL
1	13	DIAPHRAGM STEM	72976P001		ALUMINUM
1	14	SECONDARY DIAPHRAGM PLATE	72977P001	UPPER	ZINC PLATED STEEL
1	15	SECONDARY DIAPHRAGM	72968P001		BUNA-N
1	16	SECONDARY DIAPHRAGM PLATE	70012P048	LOWER	ZINC PLATED STEEL
1	17	BODY COUPLING	78134P003		ZINC PLATED STEEL
1	18	VALVE STEM	72973P001		ALUMINUM
1	19	VALVE CAGE ASSEMBLY	73524G002		ALUMINUM
1	20	BALANCING PISTON	72675P001		ZINC PLATED STEEL
1	21	FELT RING	72699P002		FELT
1	22	SEAT DISC RETAINER	72974P001	LOWER	ALUMINUM
1	23	SEAT DISC RETAINER	72970P001	UPPER	ALUMINUM
1	24	BALANCING PISTON RET. CAP	73005P001		ALUMINUM
1	25	VENT CAP	78069P005	1" NPT	PLASTIC
1	26	SPRING FOLLOWER	73261P001		ZINC PLATED STEEL
1	27	TAG	78071P051		BRASS
1	28	INSTRUCTION TAG	73790P001	NOT SHOWN	
1	29	LABEL	78482P002		ALUMINUM

Optional Parts List

QTY	ITEM #	PART NAME	PART NO.	DESCRIPTION	MATERIAL
1	52	PRESSURE SPRING	70157P028	1" - 3"	ZINC PLATED STEEL
			70157P029	3" - 7"	ZINC PLATED STEEL
			70157P030	7" - 14"	ZINC PLATED STEEL
			70157P031	14" - 28"	ZINC PLATED STEEL
			70157P032	#1 - #2	ZINC PLATED STEEL
1	55	O-RING (VALVE STEM)	78037P044	STANDARD	BUNA-N
			78037P077		VITON-A
1	56	O-RING (VALVE CAGE)	78037P045	STANDARD	BUNA-N
			78037P078		VITON-A
1	57	VALVE SEAT DISC	72969P001	STANDARD	BUNA-N
			72969P002		VITON-A
1	58	O-RING (PISTON RET. CAP)	78037P056	STANDARD	BUNA-N
			78037P080		VITON-A

Standard Spare Kits

PART NAME	PART NO.	DESCRIPTION
SPARE KIT	73913K005	INCLUDES IT# 3, 21, 55, 56, 57
SPARE KIT	73913K006	INCLUDES IT# 3, 8, 9, 10, 11, 12, 15, 21, 55, 56, 57

4" Model 3000 Industrial Regulator Assembly

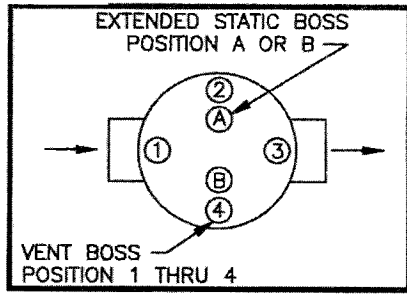

REGULATOR ASSEMBLY POSITIONS

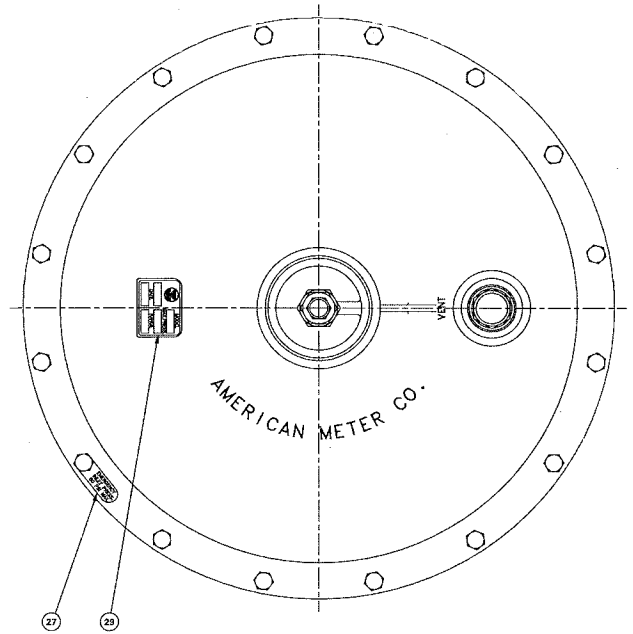

TOP VIEW

NOTES:

- INSTALL FELT RING WITH BLACK STRIPES UP. JOINT TO BE LOCATED ON VALVE INLET SIDE.

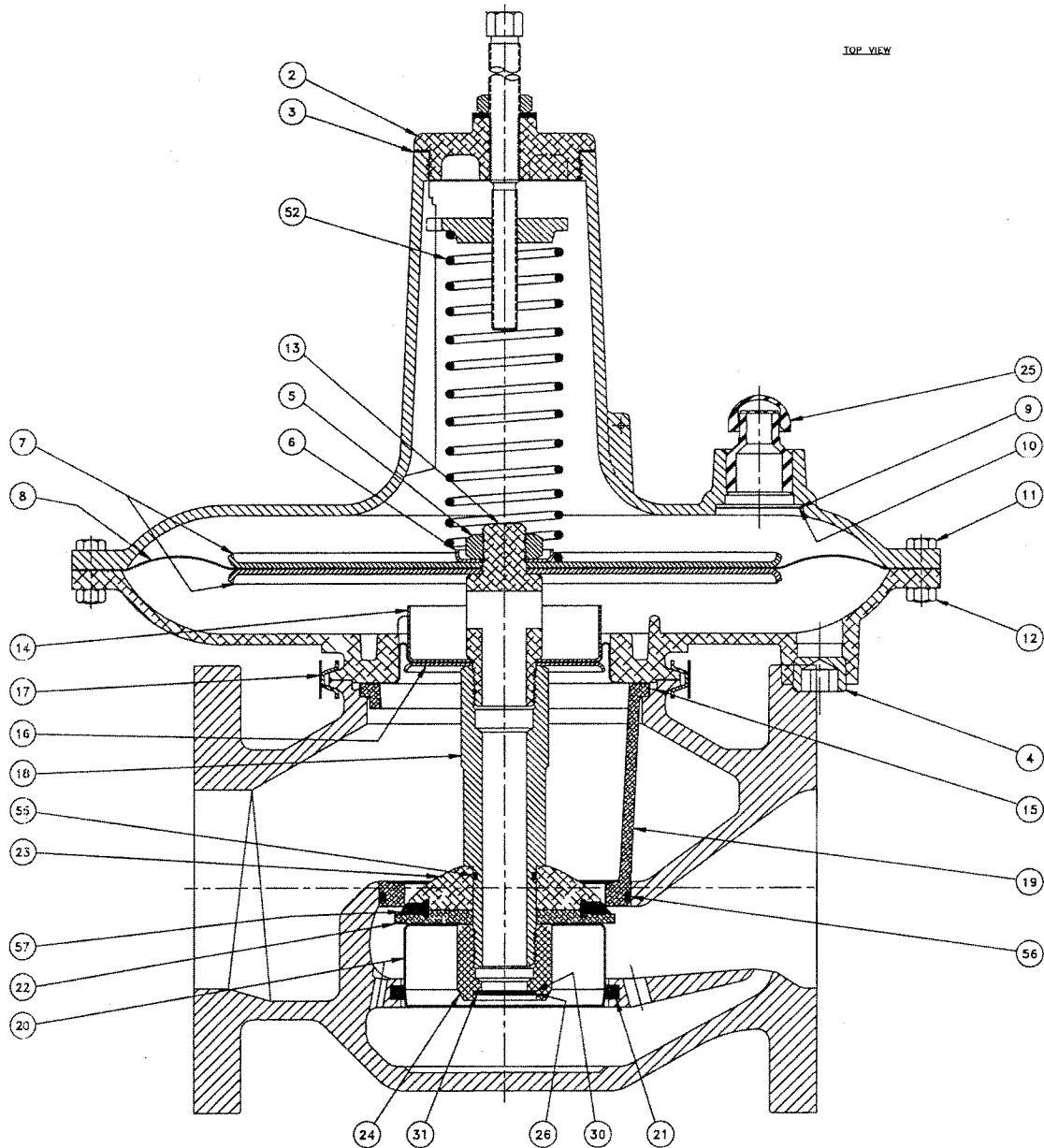

4" Model 3000 Industrial Regulator Assembly

Common Parts List

QTY	ITEM #	PART NAME	PART NO.	DESCRIPTION	MATERIAL
1	2	SEAL PLUG ASSEMBLY	73486G001		ALUMINUM
1	3	SEAL PLUG GASKET	70019P087		BUNA-N
1	4	PIPE PLUG (LOWER CHAMBER)	78039P011		ALUMINUM
1	5	DIAPHRAGM STEM NUT	78022P008	1/2-20	ZINC PLATED STEEL
1	6	SPRING GUIDE	70012P062		ZINC PLATED STEEL
2	7	DIAPHRAGM PLATE	70012P060		ZINC PLATED STEEL
1	8	DIAPHRAGM	70014P180		BUNA-N
1	9	VENT FLAPPER	72770P001		BUNA-N
1	10	RETAINING RING (VENT FLAPPER)	92943P118		ZINC PLATED STEEL
16	11	HEX HEAD CAP SCREW	78001P032	5/16-24 X 1.06 LG.	ZINC PLATED STEEL
16	12	HEX NUT	78020P003	5/16-24	ZINC PLATED STEEL
1	13	DIAPHRAGM STEM	73001P001		ALUMINUM
1	14	SECONDARY DIAPHRAGM PLATE	72993P001	UPPER	ZINC PLATED STEEL
1	15	SECONDARY DIAPHRAGM	72997P001		BUNA-N
1	16	SECONDARY DIAPHRAGM PLATE	70012P059	LOWER	ZINC PLATED STEEL
1	17	BODY COUPLING	78134P004		ZINC PLATED STEEL
1	18	VALVE STEM	73000P001		ALUMINUM
1	19	VALVE CAGE ASSEMBLY	72998P001		ALUMINUM
1	20	BALANCING PISTON	72994P001		ZINC PLATED STEEL
1	21	FELT RING	72699P007		FELT
1	22	SEAT DISC RETAINER	72996P001	LOWER	ALUMINUM
1	23	SEAT DISC RETAINER	72995P001	UPPER	ALUMINUM
1	24	BALANCING PISTON RET. NUT	73289P001		ALUMINUM
1	25	VENT CAP	78069P005	1" NPT	PLASTIC
1	26	STEM FLAPPER STOP	73329P001		ZINC PLATED STEEL
1	27	TAG	78071P051		BRASS
1	28	INSTRUCTION TAG	73790P001	NOT SHOWN	
1	29	LABEL	78482P002		ALUMINUM
1	30	VALVE STEM FLAPPER	72163P014		BUNA-N
1	31	RETAINING RING (STEM FLAPPER)	78074P009		ZINC PLATED STEEL

Optional Parts List

QTY	ITEM #	PART NAME	PART NO.	DESCRIPTION	MATERIAL
1	52	PRESSURE SPRING	71411P036	4" - 8"	ZINC PLATED STEEL
			71411P034	7" - 14"	ZINC PLATED STEEL
			71411P037	14" - 28"	ZINC PLATED STEEL
			71411P038	#1 - #2	ZINC PLATED STEEL
1	55	O-RING (VALVE STEM)	78037P064	STANDARD	BUNA-N
			78037P083		VITON-A
1	56	O-RING (VALVE CAGE)	78037P065	STANDARD	BUNA-N
			78037P084		VITON-A
1	57	VALVE SEAT DISC	72999P001	STANDARD	BUNA-N
			72999P002		VITON-A

Standard Spare Kits

PART NAME	PART NO.	DESCRIPTION
SPARE KIT	73913K007	INCLUDES IT# 3, 21, 30, 55, 56, 57
SPARE KIT	73913K008	INCLUDES IT# 3, 8, 9, 10, 11, 12, 15, 21, 30, 31, 55, 56, 57

4" Model 3010 Industrial Regulator Assembly

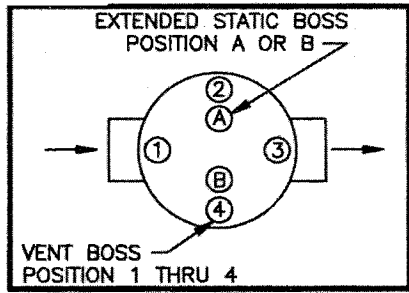

REGULATOR ASSEMBLY POSITIONS

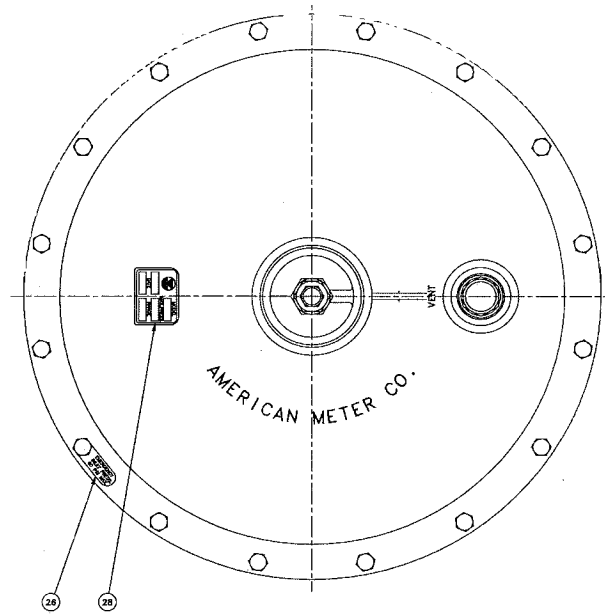

TOP VIEW

NOTES:

- INSTALL FELT RING WITH BLACK STRIPES UP. JOINT TO BE LOCATED ON VALVE INLET SIDE.

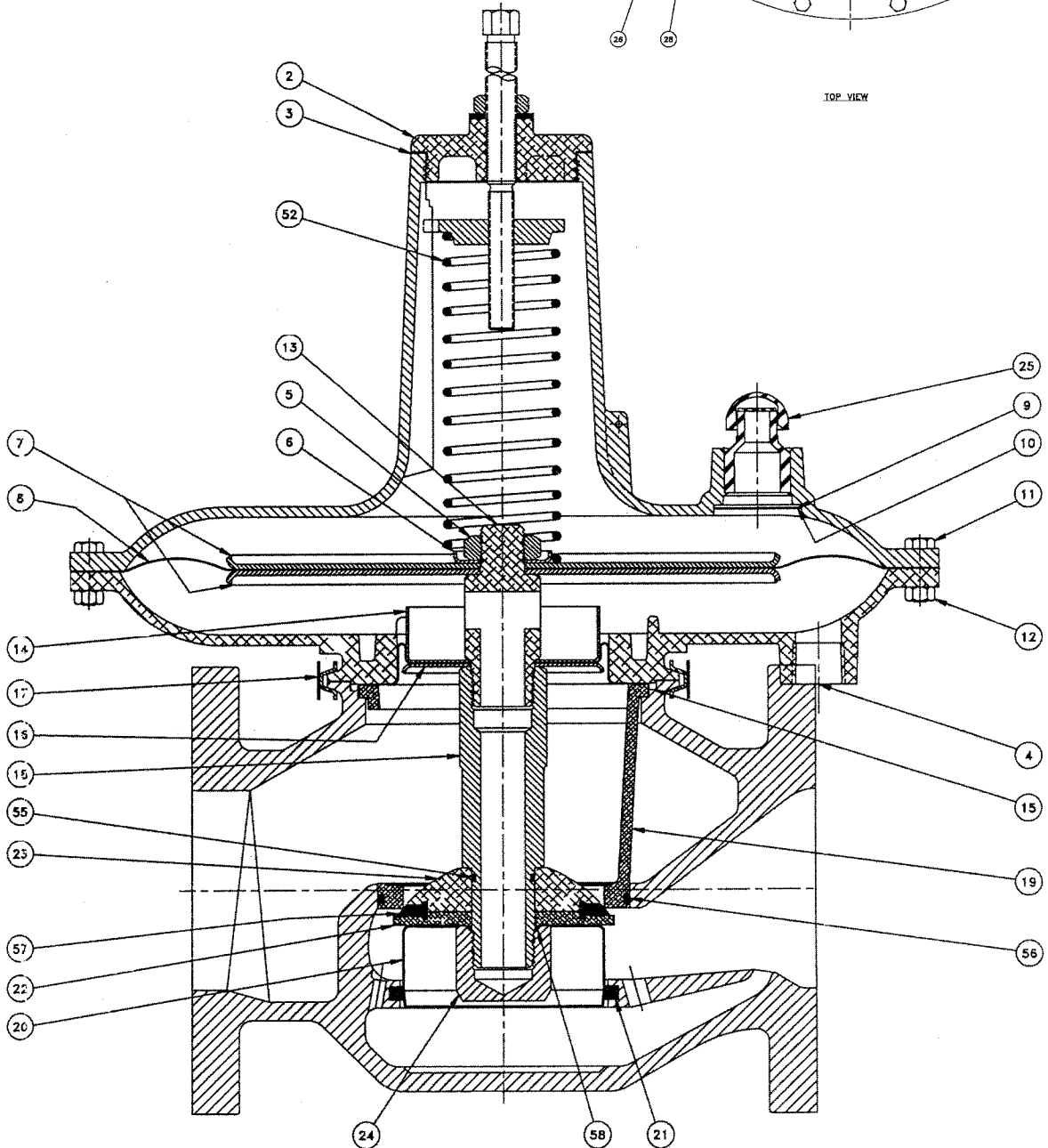

4" Model 3010 Industrial Regulator Assembly

Common Parts List

QTY	ITEM #	PART NAME	PART NO.	DESCRIPTION	MATERIAL
1	2	SEAL PLUG ASSEMBLY	73486G001		ALUMINUM
1	3	SEAL PLUG GASKET	70019P087		BUNA-N
1	4	CAPLUG	78068P047	NOT SHOWN	ALUMINUM
1	5	DIAPHRAGM STEM NUT	78022P008	1/2-20	ZINC PLATED STEEL
1	6	SPRING GUIDE	70012P062		ZINC PLATED STEEL
2	7	DIAPHRAGM PLATE	70012P060		ZINC PLATED STEEL
1	8	DIAPHRAGM	70014P180		BUNA-N
1	9	VENT FLAPPER	72770P001		BUNA-N
1	10	RETAINING RING (VENT FLAPPER)	92943P118		ZINC PLATED STEEL
16	11	HEX HEAD CAP SCREW	78001P032	5/16-24 X 1.06 LG.	ZINC PLATED STEEL
16	12	HEX NUT	78020P003	5/16-24	ZINC PLATED STEEL
1	13	DIAPHRAGM STEM	73001P001		ALUMINUM
1	14	SECONDARY DIAPHRAGM PLATE	72993P001	UPPER	ZINC PLATED STEEL
1	15	SECONDARY DIAPHRAGM	72997P001		BUNA-N
1	16	SECONDARY DIAPHRAGM PLATE	70012P059	LOWER	ZINC PLATED STEEL
1	17	BODY COUPLING	78134P004		ZINC PLATED STEEL
1	18	VALVE STEM	73000P001		ALUMINUM
1	19	VALVE CAGE ASSEMBLY	72998P001		ALUMINUM
1	20	BALANCING PISTON	72994P001		ZINC PLATED STEEL
1	21	FELT RING	72699P007		FELT
1	22	SEAT DISC RETAINER	72996P001	LOWER	ALUMINUM
1	23	SEAT DISC RETAINER	72995P001	UPPER	ALUMINUM
1	24	BALANCING PISTON RET. CAP	73290P001		ALUMINUM
1	25	VENT CAP	78069P005	1" NPT	PLASTIC
1	26	TAG	78071P051		BRASS
1	27	INSTRUCTION TAG	73790P001	NOT SHOWN	
1	28	LABEL	78482P002		ALUMINUM

Optional Parts List

QTY	ITEM #	PART NAME	PART NO.	DESCRIPTION	MATERIAL
1	52	PRESSURE SPRING	71411P036	4" - 8"	ZINC PLATED STEEL
			71411P034	7" - 14"	ZINC PLATED STEEL
			71411P037	14" - 28"	ZINC PLATED STEEL
			71411P038	#1 - #2	ZINC PLATED STEEL
1	55	O-RING (VALVE STEM)	78037P064	STANDARD	BUNA-N
			78037P083		VITON-A
1	56	O-RING (VALVE CAGE)	78037P065	STANDARD	BUNA-N
			78037P084		VITON-A
1	57	VALVE SEAT DISC	72999P001	STANDARD	BUNA-N
			72999P002		VITON-A
1	58	O-RING (PISTON CAP)	78037P041	STANDARD	BUNA-N
			78037P088		VITON-A

Standard Spare Kits

PART NAME	PART NO.	DESCRIPTION
SPARE KIT	73913K007	INCLUDES IT# 3, 21, 55, 56, 57
SPARE KIT	73913K008	INCLUDES IT# 3, 8, 9, 10, 11, 12, 15, 21, 55, 56, 57

American Meter Company is committed to a program of continuous quality enhancement. All equipment designed and manufactured by American Meter Company benefits from the company's quality assurance standards, which are approved or pending approval to ISO 9001.

American Meter Company has a program of continuous product development and improvement and therefore the information in this bulletin is subject to change or modification without notice.



AMERICAN METER

300 Welsh Road
Building One
Horsham, PA 19044-2234 USA
Phone: (215) 830-1800
Fax: (215) 830-1890
Web Site: www.americanmeter.com



CANADIAN METER

3037 Derry Road, West
Milton, Ontario, L9T 2X6 Canada
Phone: (905) 878-2361
Fax: (905) 878-5758

ELSTER  **AMCO**