

Tru/Flo™ Compound Meter

Sizes: 2" HP, 3", 4", 6", and 6" x 8"

Tru/Flo meters combine the low-flow sensitivity of a disc-type meter with the high-flow capacity of a turbine-type meter.

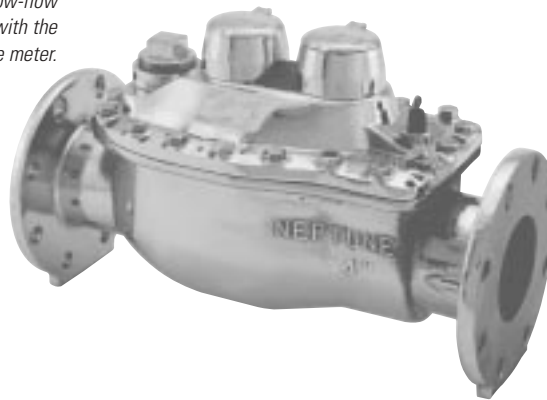

All Tru/Flo Compound water meters meet or exceed the latest performance and accuracy requirements set by the AWWA C702, and maximum continuous flow rates may be exceeded by as much as 25% for intermittent periods.

Application

The Tru/Flo Compound water meter is designed to register wide-flow ranges where varying flow rates are typical. Tru/Flo meters combine the low-flow sensitivity of a disc-type meter with the high-flow capacity of a turbine-type meter.

Operation

The hydraulic valve transfers flow smoothly between the disc section and turbine section of the meter, minimizing the loss of accuracy in the crossover range. The turbine measuring element registers high flows and the disc measuring element registers low flows, ensuring accurate measurement at all flow rates.

Construction

The Tru/Flo consists of a durable bronze maincase, Neptune Turbine measuring

element, Neptune T-10 chamber, a patented hydraulic valve, and two magnetic-driven, roll-sealed registers.

The 6" x 8" Tru/Flo assembly consists of two 8" x 6" concentric reducers, a 6" Neptune strainer, and a 6" Neptune Tru/Flo Compound meter.

The bronze maincase is corrosion resistant, lightweight, and easy to handle.

A calibration vane allows field calibration of the UME to lengthen service life and to ensure accurate registration.

The two magnetic-driven, roll-sealed registers simplify the meter's design and reduce long-term maintenance by eliminating complicated combining drive mechanisms. For reading convenience, the registers can be mounted in any one of four positions on the meter.

Systems Compatibility

Adaptability to all present and future systems for flexibility.

Key Features

- **Patented hydraulic valve design***
- **Minimum loss of accuracy in the crossover range increases revenue**
- **Spring-loaded valve eliminates need for frequent adjustment and service**
- **Combined Turbine and Disc Measuring Elements**
 - Industry-leading flow ranges at 98.5%–101.5% accuracy ensure maximum revenue
 - Direct coupling of rotor to gear train ensures accurate registration
 - Unitized Measuring Element (UME) makes maintenance easier and faster with less downtime
 - Calibration vane allows in-line service to extend life and ensure accurate registration
- **Compact Bronze Maincase**
 - Made from EnviroBrass® II
 - Compact, lightweight design provides for easy installation and in-line serviceability

*U.S. patent nos. 4,437,344 and 4,429,571

Tru/Flo™ Compound Meter

Sizes: 2" HP, 3", 4", 6", and 6"x8"

2" Accuracy

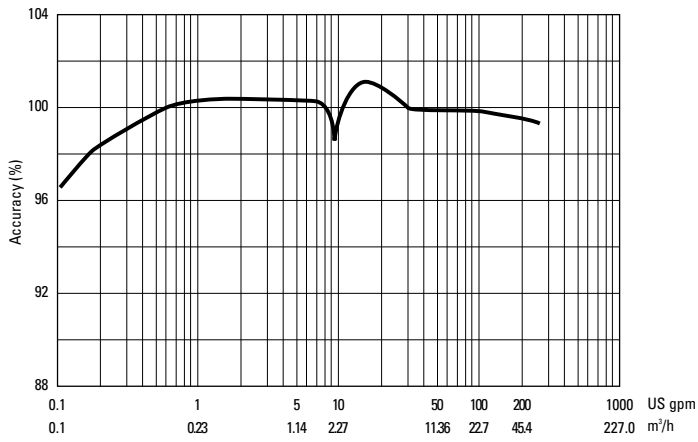

3" Accuracy

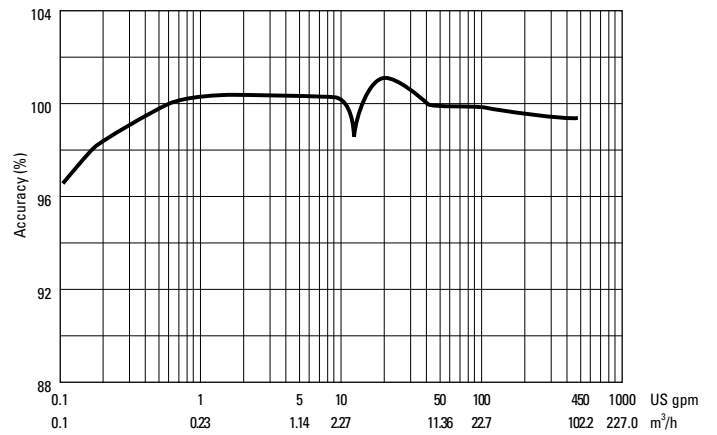

4" Accuracy

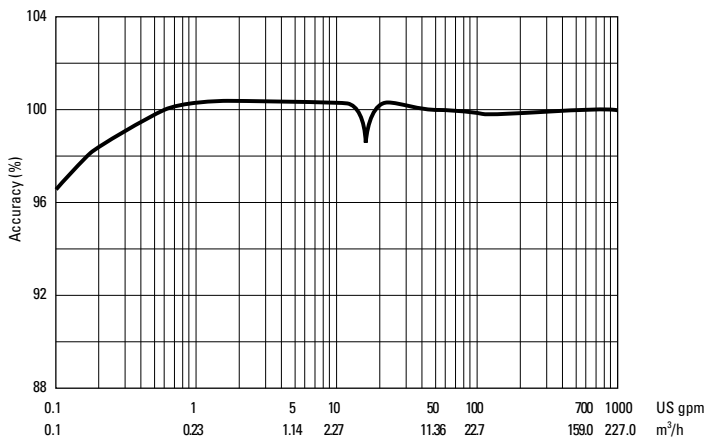

6" Accuracy

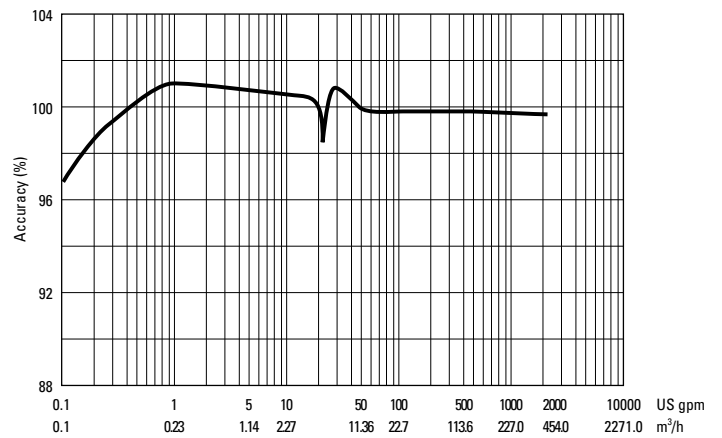

2" Pressure Loss

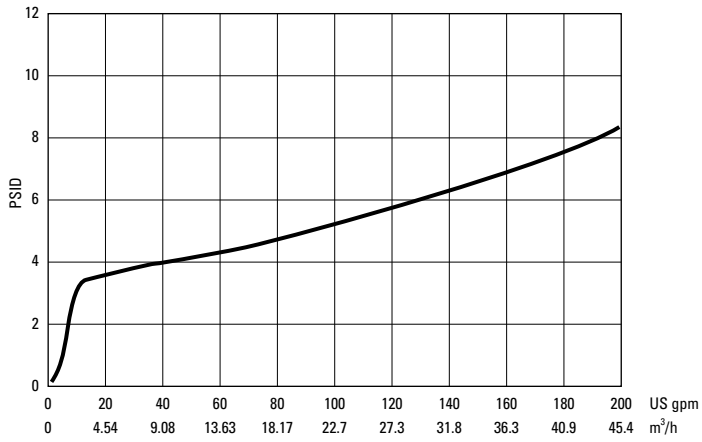

3" Pressure Loss

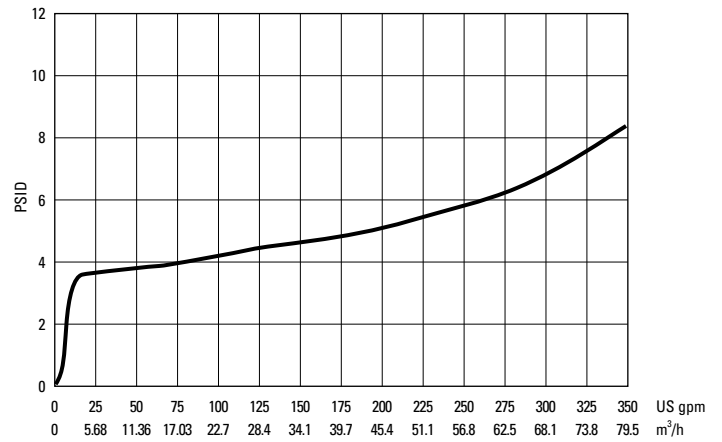

4" Pressure Loss

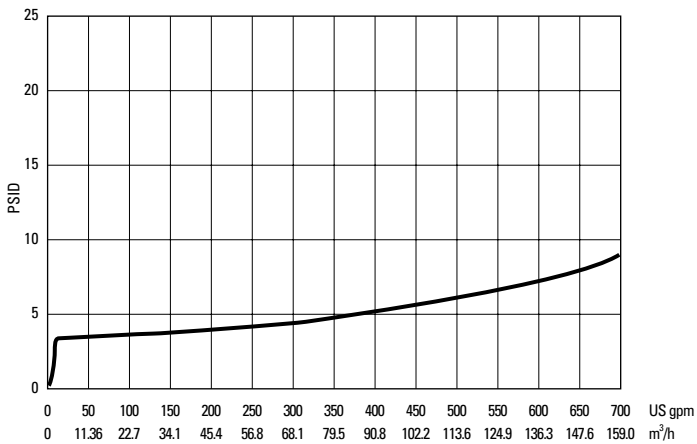

6" Pressure Loss

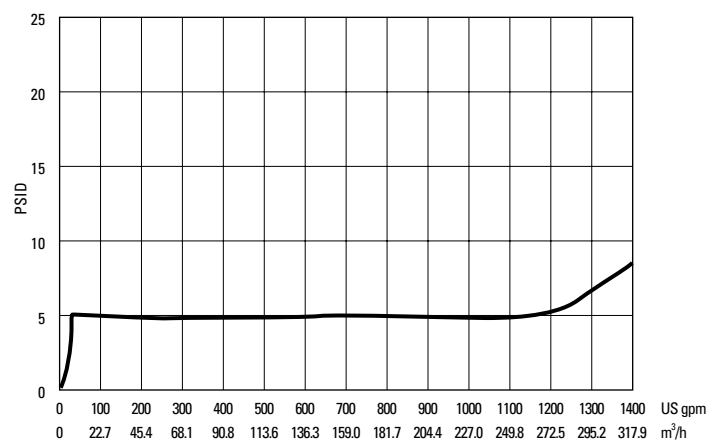

These charts show typical meter performance. Individual results may vary.

Operating Characteristics

| Meter Size | Normal Operating Range @100% Accuracy (±1.5%) | AWWA Standard | Low Flow @ 95% Accuracy |
|------------|---|---|--------------------------------------|
| 2" | 1/2 to 200 US gpm 0.11 to 45.4 m ³ /h | 2 to 160 US gpm .454 to 36.34 m ³ /h | 1/8 US gpm 0.03 m ³ /h |
| 3" | 1/2 to 450 US gpm 0.11 to 102.2 m ³ /h | 4 to 320 US gpm .91 to 72.68 m ³ /h | 1/8 US gpm 0.03 m ³ /h |
| 4" | 1 to 1000 US gpm 0.23 to 227.1 m ³ /h | 6 to 500 US gpm 1.36 to 113.56 m ³ /h | 1/2 US gpm 0.11 m ³ /h |
| 6" | 1 1/2 to 2000 US gpm 0.34 to 454.2 m ³ /h | 10 to 1000 US gpm 2.27 to 227.12 m ³ /h | 3/4 US gpm 0.17 m ³ /h |
| 6" x 8" | 1 1/2 to 2000 US gpm 0.34 to 454.2 m ³ /h | 16 to 1600 US gpm 3.63 to 363.4 m ³ /h | 3/4 US gpm 0.17 m ³ /h |

Registration

| | | Turbine Side | Disc Side |
|---|--|--------------|-------------------|
| Registration (per sweep hand revolution) | | 2", 3", 4" | 2", 3", 4", 6"x8" |
| 1,000 US Gallons | | ✓ | |
| 1,000 Imperial Gallons | | | ✓ |
| 100 US Gallons | | ✓ | |
| 100 Imperial Gallons | | ✓ | |
| 100 Cubic Feet | | | ✓ |
| 10 US Gallons | | | ✓ |
| 10 Imperial Gallons | | | ✓ |
| 10 Cubic Feet | | ✓ | |
| 10 Cubic Metres | | | ✓ |
| 1 Cubic Foot | | | ✓ |
| 1 Cubic Metre | | ✓ | |
| 0.1 Cubic Metre | | | ✓ |

| | | Turbine Side | Disc Side |
|---|--|--------------|-------------------|
| Register Capacity (6-wheel odometer) | | 2", 3", 4" | 2", 3", 4", 6"x8" |
| 1,000,000,000 US Gallons | | | ✓ |
| 1,000,000,000 Imperial Gallons | | | ✓ |
| 100,000,000 US Gallons | | ✓ | |
| 100,000,000 Imperial Gallons | | ✓ | |
| 100,000,000 Cubic Feet | | | ✓ |
| 10,000,000 US Gallons | | | ✓ |
| 10,000,000 Imperial Gallons | | | ✓ |
| 10,000,000 Cubic Feet | | ✓ | |
| 10,000,000 Cubic Metres | | | ✓ |
| 1,000,000 Cubic Feet | | | ✓ |
| 1,000,000 Cubic Metres | | ✓ | |
| 100,000 Cubic Metres | | | ✓ |

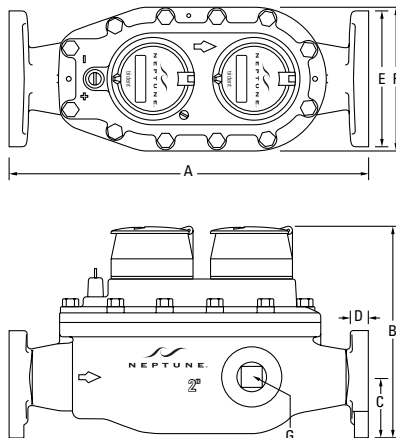

Dimensions

| Meter Size | A in/mm | B-Std in/mm | B-ARB in/mm | C in/mm | D in/mm | E in/mm | F in/mm | G in/mm | Flange Type | Weight lbs/kg |
|------------|----------------|---------------|---------------|--------------|--------------|--------------|---------------|-----------------|-------------------|---------------|
| 2" HP | 15 1/4 387 | 8 5/8 219 | 9 229 | 2 1/2 64 | 1 3/16 21 | 5 7/8 149 | 6 152 | 1 1/2 NPT 38 | 2" Oval 150 lb | 32 14.5 |
| 3" | 17 432 | 10 1/2 267 | 11 279 | 3 3/4 95 | 5/8 16 | 7 1/2 191 | 8 1/2 216 | 1 1/2 NPT 38 | 3" ANSI 150 lb | 72 32.7 |
| 4" | 20 508 | 12 1/2 318 | 13 330 | 4 1/2 114 | 1 1/16 17 | 9 229 | 9 1/8 232 | 2 NPT 51 | 4" ANSI 150 lb | 100 45.4 |
| 6" | 24 610 | 15 3/4 400 | 16 1/4 413 | 5 1/2 140 | 1 25 | 11 279 | 12 3/4 324 | 2 NPT 51 | 6" ANSI 150 lb | 208 94.3 |
| 6"x8" | 55 3/8 1407 | 15 3/4 400 | 16 1/4 413 | 5 1/2 140 | 1 25 | 11 279 | 12 3/4 324 | 2 NPT 51 | 6" ANSI 150 lb | 460 208.5 |

Warranty

Neptune provides a limited warranty with respect to its Tru/Flo Compound water meters for performance, materials and workmanship.

When desired, owner maintenance is easily accomplished by in-line replacement of major components, or a factory calibrated UME.

Guaranteed Systems Compatibility

All Neptune Tru/Flo Compound meters are guaranteed adaptable to our ARB®V, ProRead AutoDetect, TRICON®/S, TRICON/E3®, and Neptune meter reading systems without removing the meter from service.

Specifications

- Application: cold water measurement of flow in one direction
- Maximum operating pressure: 150 psi (1206 kPa)
- Maximum operating temperature: 80°F
- Register: direct reading, center sweep, roll-sealed, magnetic drive with low-flow indicator
- Measuring element:
 - AWWA Class II Turbine, dual suspension
 - Nutating disc

Options

- Sizes: 2"HP, 3", 4", 6", and 6"x8"
- Units of measure: U.S. gallons, imperial gallons, cubic feet, cubic metres
- Register types:
 - Direct reading: bronze box and cover (standard)
 - Remote reading systems*: ProRead AutoDetect, TRICON/S, TRICON/E3
 - Reclaim
- Companion flanges:
 - 2", 3", 4" bronze or cast iron
 - 6", 6" x 8" cast iron
- Strainer: 2", 3", 4", 6" bronze

* Consult factory for meter performance specifications when fitted with ARB.



www.neptunetg.com

Neptune Technology Group Inc.
1600 Alabama Highway 229
Tallahassee, AL 36078, USA
Tel: (800) 645-1892
Fax: (334) 283-7299

Neptune Technology Group Inc.
7275 West Credit Avenue
Mississauga, Ontario L5N 5M9, Canada
Tel: (905) 858-4211
Fax: (905) 858-0428

Neptune Technology Group Inc.
Via Gustavo Baz No. 29-C
Col. Naucalpan Centro
53000 Naucalpan, Estado de México
Tel: (525) 358-8737
Fax: (525) 576-1934